



Table of Contents

	Page
Tips	2
Dispersion Disc	2
Extension Replacement Tips	3
Shutoff Nozzle Tip	3
 Replacement Nozzles for following type presses. . .	
Arburg Type	4-5
Cincinnati Type	5-6
HPM Type	7
JSW (Japan Steel) Type	8
Kawaguchi Type	8-9
Nissei Type	9-11
New Britian Type	11
Newbury Type	13
Reed Type	12
Toshiba Type	13-14
Toyo Type	15
Van Dorn Type	16
Van Dorn & Beloit Type	17
Nozzle Heater Bands	18
Internal Heat Installation	18
Ring Check Valves	19-20
Nozzle Thread/Metal Filter Adaptors	20-21
Nozzle Tip Adaptors	20
Specialized Parts Made To Order	22
 Mold Clamp Assemblies . . .	
Open Slot Style/Heavy Duty	23
Open Slot Style/Extra Heavy Duty	24
Enclosed Slot Style/Extra Heavy Duty	25
Open Slot Style/Heavy Duty	26
Enclosed Slot Style for T-Slotted Machines/ Extra Heavy Duty	27
Individual Mold Clamp Bodies	28
Individual Accessory and Replacement Mold Clamp Parts	28-29

Prices Effective: October 30, 2000

Prices subject to change without notice.

This price list supersedes all previously printed price schedules.

All orders are shipped F.O.B. Redford, Michigan

Terms: Net 30 Days

HTC/TOPS-ALL Clamps, Inc.

26627 West 8 Mile Road, Redford, MI 48240

Phone: (313) 533-7500 □ Fax: (313) 533-1040 □ www.htc-topsallclamps.com

Nozzles, Etc.

We believe the HTC/TOPS-ALL products in this catalog are of the highest quality and workmanship. The widespread use of these injection nozzles and tips, non-return valves, injection mold clamps and accessories is assurance of their quality and

value. We maintain this quality by using only premium steels and the best toolmakers in the industry.

On pages two through twenty-one, you'll find a variety of the nozzles and other related prod-

ucts to fit most any new or existing injection mold press. If you need products built to your exact requirements, see page twenty-two for special ordering information.

Please Note:

- Nozzles supplied for all plunger and reciprocating screw presses, one piece or replaceable tip construction.
- Metric thread capability for foreign made presses.
- Immediate shipment of stock items.
- A sketch or sample of your requirements for unlisted nozzles will receive immediate attention.



Clamps, Etc.

As the pioneers of the swivel-based adjusting screw, HTC/TOPS-ALL now offers the

most complete line of injection mold clamps available. There are four styles in twenty-five sizes. The exclusive swivel-based screw permits fast, sure adjustments, protects platen against scoring, eliminates threaded bolt hole distortions, and reduces set-up time. With a tilting action, the swivel base even adjusts to uneven platen surfaces.

MOLD CLAMPING TIPS

Place clamping bolt as close to mold as possible to obtain the maximum mold holding leverage pressure, adjust clamp to a parallel "X" position in relation to platen, and insert at least one



times the diameter in length of bolt thread "Y" into platen.

Clamps must be set parallel to press platen which is critical for equal clamping pressure to entire mold. The proper set-up, adequate number of clamps and correct size of clamps in relation to mold size and break-away pressure will insure safer and better mold set-ups and decrease production down time.

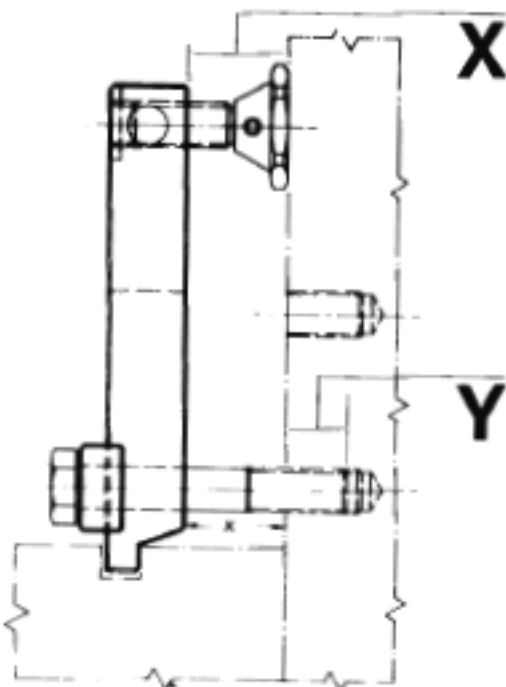

Tips - 7/8 - 14 Thread

Replaceable Tips offer many Advantages for Injection Molders

Two Hardness Levels and Beryllium-Type materials available.

Please contact factory for price and availability on Arburg, Nissei, Kawaguchi, and Kona style replaceable nozzle tips.

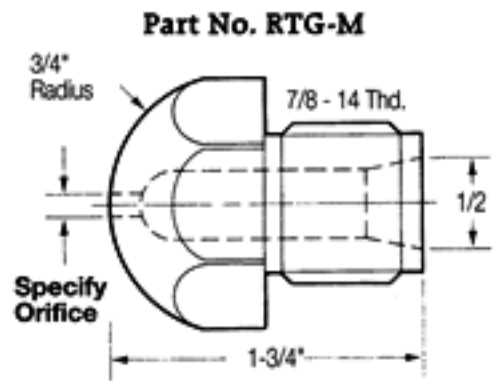

Large Radius Surface Tip
with 1-1/4" Hex, Radius 3/4", Orifice 1/16" thru 3/8", OAL 1-3/4".

General Purpose Tip \$45.00
Nylon and Full Taper available upon request.

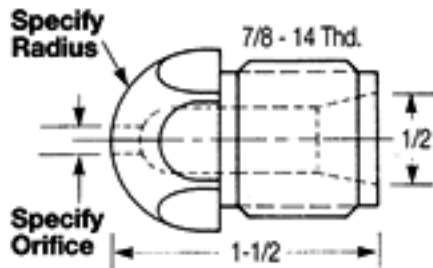

Specify: 1/2 or 3/4 Tip Radius
1/16 through 3/8 Orifice

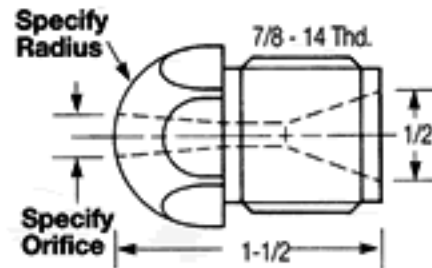

Specify: 1/2 or 3/4 Tip Radius
1/8, 5/32, 3/16 or 1/4 Orifice

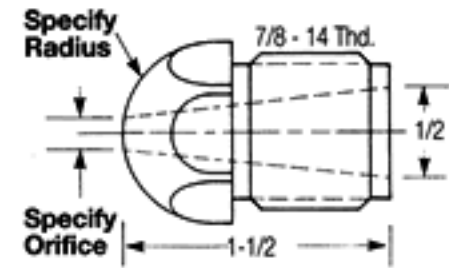

Specify: 1/2 or 3/4 Tip Radius
1/8, 5/32, 3/16, 1/4 or 3/8 Orifice



Add \$9.00 for Special Orifice
Size if less than 6 units



GENERAL PURPOSE TIP		
Part Number	Material	Price Each
RTG*	Rc37 Tool Steel	\$17.*
RTG-S	Rc45 Tool Steel	\$19.
RTG-B	Beryllium	\$32.

*RTG 1-5 \$17. / 6-11 \$15. / 12 or more \$13.

NYLON TIP		
Part Number	Material	Price Each
RTN*	Rc37 Tool Steel	\$17.*
RTN-S	Rc45 Tool Steel	\$19.
RTN-B	Beryllium	\$32.

*RTN 1-5 \$17. / 6-11 \$15. / 12 or more \$13.

FULL TAPER TIP		
Part Number	Material	Price Each
RTT*	Rc37 Tool Steel	\$21.*
RTT-S	Rc45 Tool Steel	\$23.
RTT-B	Beryllium	\$34.

*RTT 1-5 \$21. / 6-11 \$19. / 12 or more \$17.

Dispersion Disc

Installed in nozzle tip. Advantages: quick access, improved color mixing, prevents foreign material passage.

Counterbored to receive HTC 9/16 Dia. Dispersion Discs.

Part No.
RTG-D \$29
Specify:
1/2 or 3/4
Tip Radius
1/16 through
3/8 Orifice

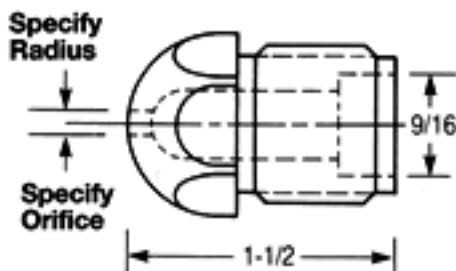

Can be used behind any tip - general purpose, nylon or full taper.



19 Holes .025 Dia.
Part No. D-34-025 \$15.00

19 Holes .050 Dia.
Part No. D-34-050 \$10.00



19 Holes .025 Dia.
Part No. D-025 \$15.00

19 Holes .050 Dia.
Part No. D-050 \$10.00

7 Holes .085 Dia.
Part No. D-085 \$12.00
(not shown)

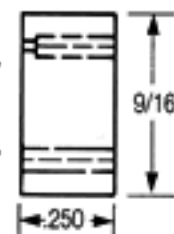

Extension Replacement Tips - 7/8 - 14 Thread

for HTC and all other Replaceable Tip Nozzles

Two Hardness Levels

General Purpose
Extension Tips

Specify: 1/2 or 3/4 Tip Radius
1/16 through 3/8 Orifice

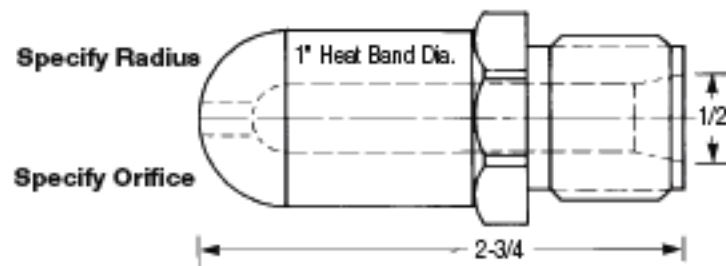

HTC STANDARD Rc37		
Part Number	Length	Price Each
RTX-GR	2-3/4	\$37.
RTX-GR4	4	\$47.
RTX-GR5	5	\$58.
RTX-GR6	6	\$73.
RTX-GR8	8	\$105.

HEAT TREATED Rc45		
Part Number	Length	Price Each
RTX-GRS	2-3/4	\$40.
RTX-GR4S	4	\$50.
RTX-GR5S	5	\$61.
RTX-GR6S	6	\$76.
RTX-GR8S	8	\$108.

BERYLLIUM		
Part Number	Length	Price Each
RTX-GRB	2-3/4	\$70.

Nylon Extension Tips

Specify: 1/2 or 3/4 Tip Radius
1/8, 5/32 or 3/16 Orifice
Add \$9.00 for Special Orifice
Size if less than 6 units

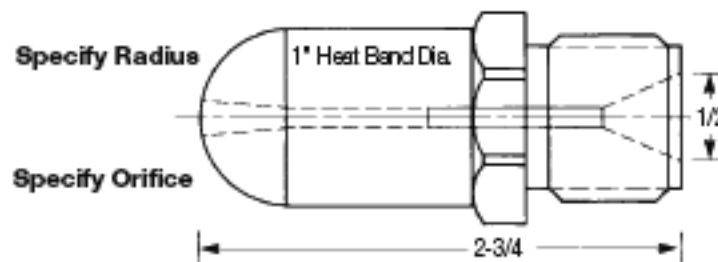

HTC STANDARD Rc37		
Part Number	Length	Price Each
RTX-NR	2-3/4	\$42.
RTX-NR4	4	\$60.
RTX-NR5	5	\$70.
RTX-NR6	6	\$85.

HEAT TREATED Rc45		
Part Number	Length	Price Each
RTX-NRS	2-3/4	\$45.
RTX-NR4S	4	\$63.
RTX-NR5S	5	\$73.
RTX-NR6S	6	\$88.

BERYLLIUM		
Part Number	Length	Price Each
RTX-NRB	2-3/4	\$80.

Shutoff Nozzle Tip

Minimize nozzle drool and sink patterns. Instantly installed in HTC replacement tip nozzles.

1/16 Orifice requires 7/32 minimum sprue bushing.
1/8 Orifice requires 9/32 minimum sprue bushing.
3/16 Orifice requires 5/16 minimum sprue bushing.

The spring loaded valve in nozzle tip restricts movement of material until activated by pressure. Opens in the direction of the sprue bushing and closes until recycled.

(Nozzle Body not included)



Assembled Photograph

Part No. SHUTOFF \$83.00
Specify: 1/2 or 3/4 Tip Radius
1/16, 1/8 or 3/16 Orifice

COMPONENTS

Stem - \$16.50
Torpedo-\$14.50
Spring-\$3.00
Tip-\$49.00

HTC/TOPS-ALL Clamps, Inc.

26627 West 8 Mile Road, Redford, MI 48240 ☐ Phone: (313) 533-7500 ☐ Fax: (313) 533-1040 ☐ www.htc-topsallclamps.com

Arburg - 45 x 1.5 & 45 x 2 Thread

Replacement Nozzles for Arburg Type Presses.

Body with Tip Installed.

Specify To Order:

Code Number	Thread Size	Rear Opening
-1	45 x 1.5**	22 mm
-2	45 x 1.5 LH	25 mm
-3	45 x 1.5 LH	30 mm
-4	45 x 2 LH	18 mm
-5	45 x 2 LH	22 mm
-6	45 x 2 LH	25 mm
-7	45 x 2 LH	30 mm

**Specify Right or Left Hand Thread

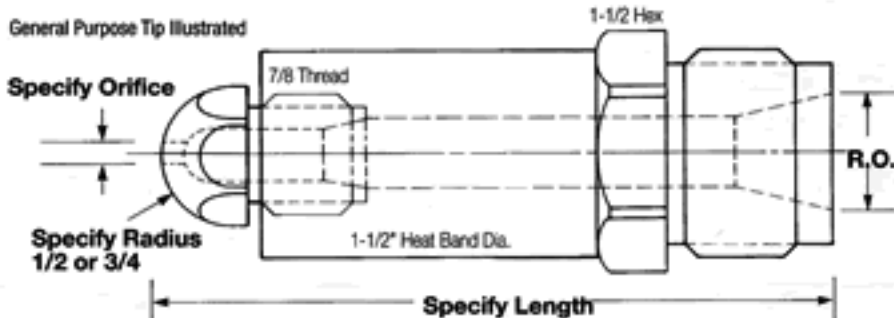

Specify: Code Number, Tip Radius & Orifice
Thread on Nozzle Body is 7/8 -14
For M24 x 1.5 mm add \$21.00 & Specify

GENERAL PURPOSE - TIP INSTALLED			
Part Number	Length	Heater Width	Price Each
AR5G	5"	2"	\$131.
AR6G	6"	3"	\$144.

NYLON DESIGN - TIP INSTALLED			
Part Number	Length	Heater Width	Price Each
AR5N	5"	2"	\$131.
AR6N	6"	3"	\$144.

FULL TAPER- TIP INSTALLED			
Part Number	Length	Heater Width	Price Each
AR5T	5"	2"	\$135.
AR6T	6"	3"	\$148.

Arburg - 35 x 1.5 & 35 x 2

Replacement Nozzles for Arburg Type Presses.

Body with Tip Installed.

Specify To Order:

Code Number	Thread Size	Rear Opening
-1	35 x 1.5**	18 mm
-2	35 x 2mm LH	18 mm

**Specify Right or Left Hand Thread

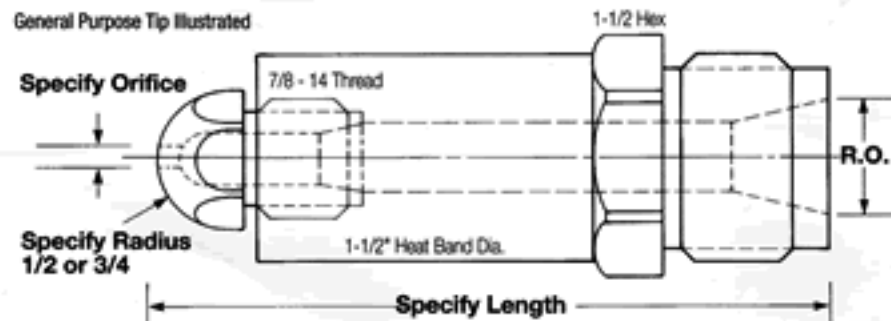

Specify: Code Number, Tip Radius & Orifice

GENERAL PURPOSE - TIP INSTALLED			
Part Number	Length	Heater Width	Price Each
AB5G	5"	2"	\$94.
AB6G	6"	3"	\$104.
AB7G	7"	4"	\$124.
AB8G	8"	5"	\$144.
AB9G	9"	6"	\$158.
AB10G	10"	7"	\$177.
AB12G	12"	9"	\$216.

NYLON DESIGN - TIP INSTALLED			
Part Number	Length	Heater Width	Price Each
AB5N	5"	2"	\$94.
AB6N	6"	3"	\$104.
AB7N	7"	4"	\$124.
AB8N	8"	5"	\$144.
AB9N	9"	6"	\$158.
AB10N	10"	7"	\$177.
AB12N	12"	9"	\$216.

FULL TAPER - TIP INSTALLED			
Part Number	Length	Heater Width	Price Each
AB5T	5"	2"	\$98.
AB6T	6"	3"	\$108.
AB7T	7"	4"	\$128.
AB8T	8"	5"	\$148.
AB9T	9"	6"	\$162.
AB10T	10"	7"	\$181.
AB12T	12"	9"	\$220.

Arburg - 8 Sizes

Replacement Nozzles for Arburg Type Presses.

Body with Tip Installed.

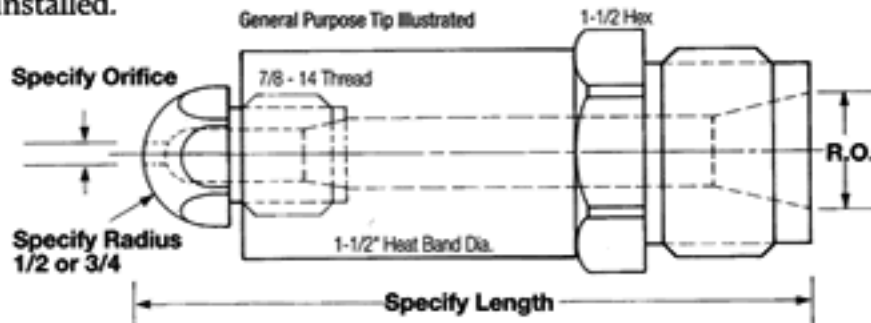

Specify: Code Number, Tip Radius & Orifice
Thread on Nozzle Body is 7/8 - 14
For M24 x 1.5 mm add \$21.00 & Specify

Specify To Order:

Code Number	Thread Size	Rear Opening
-1	50 x 2 LH	30 mm
-2	50 x 2 LH	35 mm
-3	52 x 2**	30 mm
-4	52 x 2**	35 mm
-5	52 x 2**	40 mm
-6	55 x 2**	30 mm
-7	55 x 2 LH	40 mm
-8	60 x 2 LH	45 mm

**Specify Right or Left Hand Thread

See page 2 for available tips



GENERAL PURPOSE - TIP INSTALLED			
Part Number	Length	Heater Width	Price Each
AG5G	5"	2"	\$136.
AG6G	6"	3"	\$146.
AG7G	7"	4"	\$161.
AG8G	8"	5"	\$171.

NYLON DESIGN - TIP INSTALLED			
Part Number	Length	Heater Width	Price Each
AG5N	5"	2"	\$136.
AG6N	6"	3"	\$146.
AG7N	7"	4"	\$161.
AG8N	8"	5"	\$171.

FULL TAPER - TIP INSTALLED			
Part Number	Length	Heater Width	Price Each
AG5T	5"	2"	\$140.
AG6T	6"	3"	\$150.
AG7T	7"	4"	\$165.
AG8T	8"	5"	\$175.

Cincinnati - 1 3/4 - 8 & 1 1/2 - 12 Thread

Replacement Nozzles for Cincinnati Type Presses.

Body with Tip Installed.

Specify To Order:

Code Number	Thread Size	Rear Opening	Thread Length
-1	1-3/4-8	3/4"	1-5/8"
-2	1-1/2-12	1/2"	1-7/8"

Specify: Code Number,
Tip Radius & Orifice

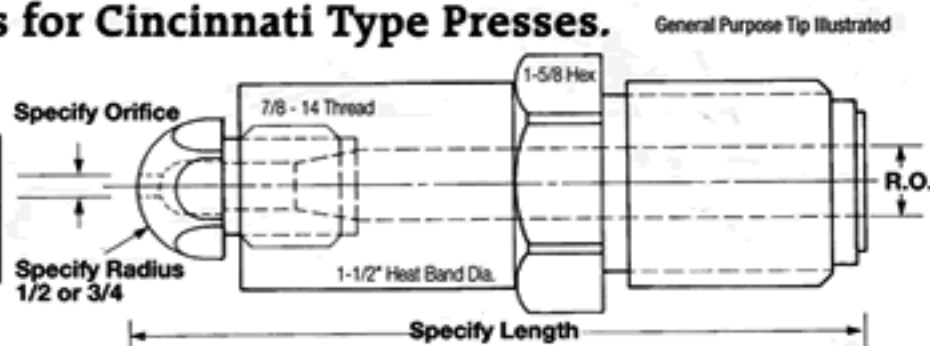

GENERAL PURPOSE- TIP INSTALLED			
Part Number	Length	Heater Width	Price Each
C5G	5"	1-1/2"	\$86.
C6G	6"	2-1/2"	\$97.
C7G	7"	3-1/2"	\$108.
C8G	8"	4-1/2"	\$118.
C9G	9"	5-1/2"	\$131.
C10G	10"	6-1/2"	\$145.
C12G	12"	8-1/2"	\$168.
C18G	18"	14-1/2"	\$240.

NYLON DESIGN - TIP INSTALLED			
Part Number	Length	Heater Width	Price Each
C5N	5"	1-1/2"	\$86.
C6N	6"	2-1/2"	\$97.
C7N	7"	3-1/2"	\$108.
C8N	8"	4-1/2"	\$118.
C9N	9"	5-1/2"	\$131.
C10N	10"	6-1/2"	\$145.
C12N	12"	8-1/2"	\$168.
C18N	18"	14-1/2"	\$240.

FULL TAPER- TIP INSTALLED			
Part Number	Length	Heater Width	Price Each
C5T	5"	1-1/2"	\$90.
C6T	6"	2-1/2"	\$101.
C7T	7"	3-1/2"	\$112.
C8T	8"	4-1/2"	\$122.
C9T	9"	5-1/2"	\$135.
C10T	10"	6-1/2"	\$149.
C12T	12"	8-1/2"	\$172.
C18T	18"	14-1/2"	\$244.

HTC/TOPS-ALL Clamps, Inc.

26627 West 8 Mile Road, Redford, MI 48240 ☐ Phone: (313) 533-7500 ☐ Fax: (313) 533-1040 ☐ www.htc-topsallclamps.com

Cincinnati - 1-1/4 - 12 & 1-1/2 - 12 Thread

Replacement Nozzles for Cincinnati Type Presses.

Body with Tip Installed.

Specify To Order:

Code Number	Thread Size	Rear Opening	Thread Length
-1	1-1/4-12	.743	3/4"
-2	1-1/2-12	.630	1.495"

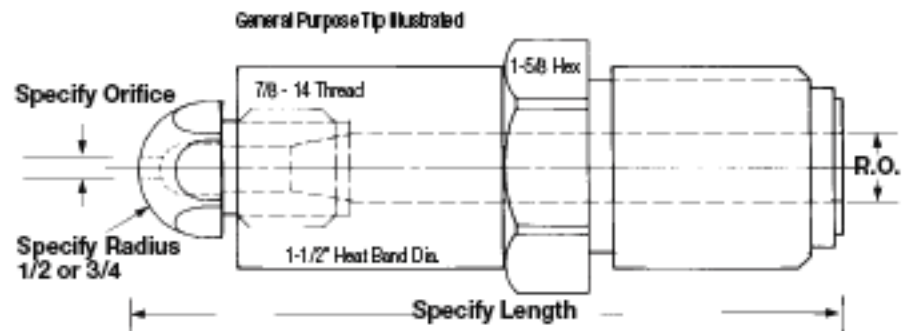

Specify: Code Number, Tip Radius & Orifice

1/8", 1/4", 10-24 or OEM type Thermowell add \$10.00

3/8-24 Melt Thermo or 1/2-20 Transducer Hole add \$22.00

GENERAL PURPOSE - TIP INSTALLED			
Part Number	Length	Heater Width	Price Each
CN5G	5"	1-1/2"	\$86.
CN6G	6"	2-1/2"	\$97.
CN7G	7"	3-1/2"	\$108.
CN8G	8"	4-1/2"	\$118.
CN9G	9"	5-1/2"	\$131.
CN10G	10"	6-1/2"	\$145.
CN12G	12"	8-1/2"	\$168.

NYLON DESIGN - TIP INSTALLED			
Part Number	Length	Heater Width	Price Each
CN5N	5"	1-1/2"	\$86.
CN6N	6"	2-1/2"	\$97.
CN7N	7"	3-1/2"	\$108.
CN8N	8"	4-1/2"	\$118.
CN9N	9"	5-1/2"	\$131.
CN10N	10"	6-1/2"	\$145.
CN12N	12"	8-1/2"	\$168.

FULL TAPER - TIP INSTALLED			
Part Number	Length	Heater Width	Price Each
CN5T	5"	1-1/2"	\$90.
CN6T	6"	2-1/2"	\$101.
CN7T	7"	3-1/2"	\$112.
CN8T	8"	4-1/2"	\$122.
CN9T	9"	5-1/2"	\$135.
CN10T	10"	6-1/2"	\$149.
CN12T	12"	8-1/2"	\$172.

Cincinnati - 2" - 8 Thread

Replacement Nozzles for Cincinnati Type Presses.

Body with Tip Installed.

Specify: Tip Radius & Orifice

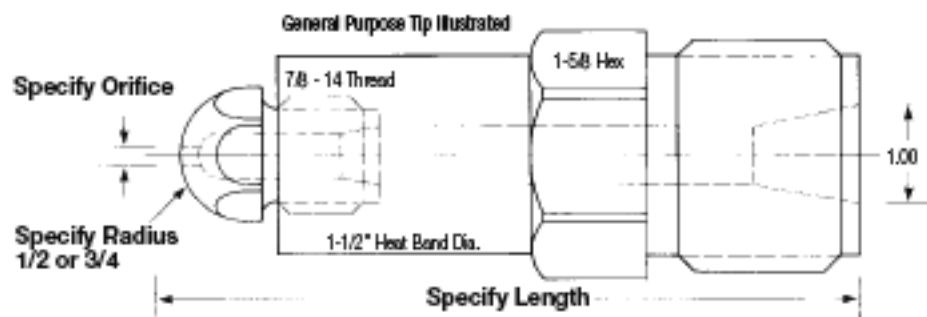

GENERAL PURPOSE - TIP INSTALLED			
Part Number	Length	Heater Width	Price Each
CCN5G	5"	1-1/2"	\$131.
CCN6G	6"	2-1/2"	\$144.
CCN7G	7"	3-1/2"	\$164.
CCN8G	8"	4-1/2"	\$169.
CCN9G	9"	5-1/2"	\$201.
CCN10G	10"	6-1/2"	\$220.
CCN12G	12"	8-1/2"	\$267.

NYLON DESIGN - TIP INSTALLED			
Part Number	Length	Heater Width	Price Each
CCN5N	5"	1-1/2"	\$131.
CCN6N	6"	2-1/2"	\$144.
CCN7N	7"	3-1/2"	\$164.
CCN8N	8"	4-1/2"	\$169.
CCN9N	9"	5-1/2"	\$201.
CCN10N	10"	6-1/2"	\$220.
CCN12N	12"	8-1/2"	\$267.

FULL TAPER - TIP INSTALLED			
Part Number	Length	Heater Width	Price Each
CCN5T	5"	1-1/2"	\$135.
CCN6T	6"	2-1/2"	\$148.
CCN7T	7"	3-1/2"	\$168.
CCN8T	8"	4-1/2"	\$173.
CCN9T	9"	5-1/2"	\$205.
CCN10T	10"	6-1/2"	\$224.
CCN12T	12"	8-1/2"	\$271.

HPM Type - Clamp Nut & Nozzle - 1" I.D.

Replacement Nozzles for HPM Type Presses.

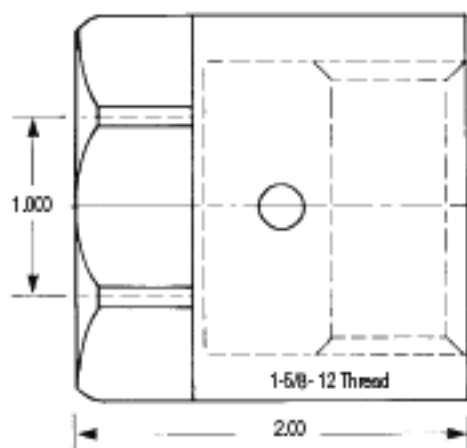

Retaining Nut
Part No. H1CN- \$95.

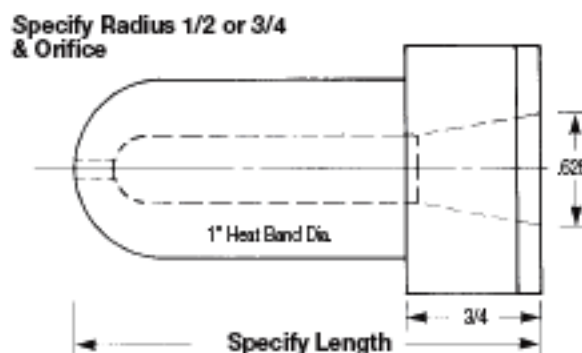

GENERAL PURPOSE		
SPECIFY RADIUS & ORIFICE		
Part Number	Length	Price Each
H263-1G	2-5/8"	\$78.
H300-1G	3"	\$88.
H400-1G	4"	\$99.
H500-1G	5"	\$109.
H600-1G	6"	\$119.
Price Does Not Include Nut.		

NYLON DESIGN		
SPECIFY RADIUS & ORIFICE		
Part Number	Length	Price Each
H263-1N	2-5/8"	\$93.
H300-1N	3"	\$103.
H400-1N	4"	\$114.
H500-1N	5"	\$124.
H600-1N	6"	\$134.
Price Does Not Include Nut.		

Clamp Nut & Nozzle - 1.125" I.D.

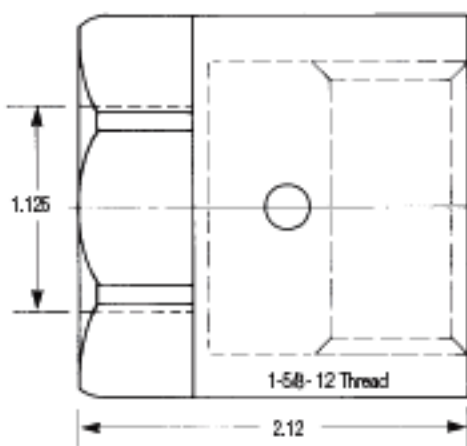

Retaining Nut
Part No. H125CN- \$95.

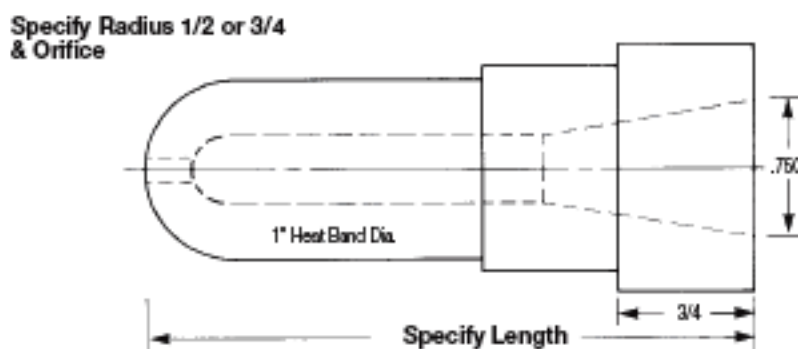

GENERAL PURPOSE		
SPECIFY RADIUS & ORIFICE		
Part Number	Length	Price Each
H263-125G	2-5/8"	\$78.
H300-125G	3"	\$88.
H400-125G	4"	\$99.
H500-125G	5"	\$109.
H600-125G	6"	\$119.
Price Does Not Include Nut.		

NYLON DESIGN		
SPECIFY RADIUS & ORIFICE		
Part Number	Length	Price Each
H263-125N	2-5/8"	\$93.
H300-125N	3"	\$103.
H400-125N	4"	\$114.
H500-125N	5"	\$124.
H600-125N	6"	\$134.
Price Does Not Include Nut.		

HTC/TOPS-ALL Clamps, Inc.

26627 West 8 Mile Road, Redford, MI 48240 ☐ Phone: (313) 533-7500 ☐ Fax: (313) 533-1040 ☐ www.htc-topsallclamps.com

JSW (Japan Steel) - 5 Sizes

Replacement Nozzles for JSW Type Presses.

Body with Tip Installed.

Specify To Order:

Code Number	Thread Size	Rear Opening
-1	1.945 x 3	15 mm
-2	44 x 3	20 mm
-3	55 x 3	8 mm
-4	55 x 3	.500
-5	50 x 3	.590

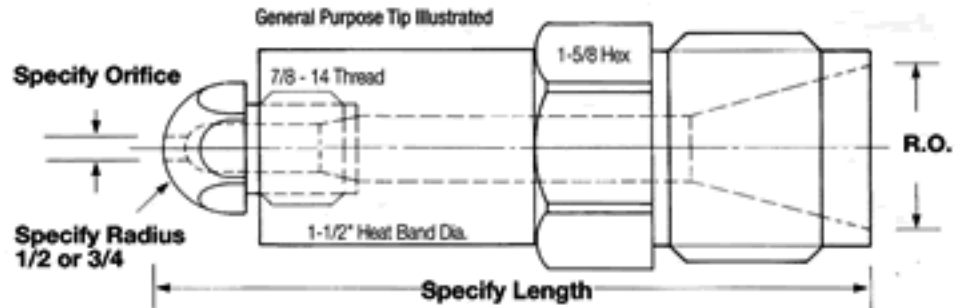

Specify: Tip Radius & Orifice

1/8", 1/4," 10-24 or OEM Type Thermowell add \$10

3/8-24 Melt Thermo or 1/2-20 Transducer Hole add \$22

GENERAL PURPOSE - TIP INSTALLED			
Part Number	Length	Heater Width	Price Each
JS5G	5"	C o n t a c t o r y	\$113.
JS6G	6"		\$128.
JS7G	7"		\$142.
JS8G	8"		\$157.
JS9G	9"		\$172.
JS10G	10"		\$188.
JS12G	12"		\$217.

NYLON DESIGN - TIP INSTALLED			
Part Number	Length	Heater Width	Price Each
JS5N	5"	C o n t a c t o r y	\$113.
JS6N	6"		\$128.
JS7N	7"		\$142.
JS8N	8"		\$157.
JS9N	9"		\$172.
JS10N	10"		\$188.
JS12N	12"		\$217.

FULL TAPER - TIP INSTALLED			
Part Number	Length	Heater Width	Price Each
JS5T	5"	C o n t a c t o r y	\$117.
JS6T	6"		\$132.
JS7T	7"		\$146.
JS8T	8"		\$161.
JS9T	9"		\$176.
JS10T	10"		\$192.
JS12T	12"		\$221.

Kawaguchi - 1-3/4 - 8 & 1-1/4 - 12 Threads

Replacement Nozzles for Kawaguchi Type Presses.

Body with Tip Installed.

Specify To Order:

Code Number	Thread Size	Rear Opening
-1	1-3/4-8	.938
-2	1-1/4-12	.938
-3	1-1/4-12	.875

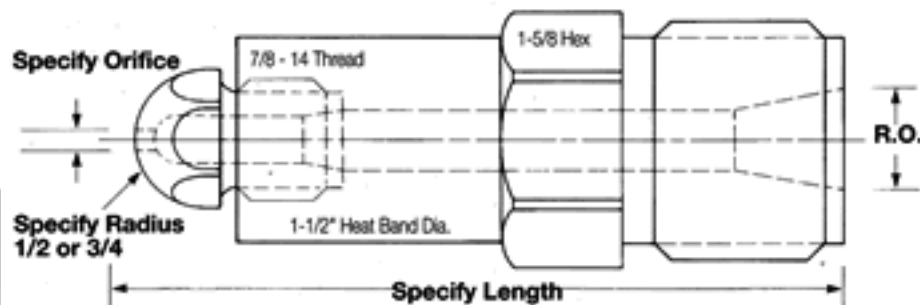

General Purpose Tip Illustrated

Specify: Tip Radius & Orifice



GENERAL PURPOSE - TIP INSTALLED			
Part Number	Length	Heater Width	Price Each
K5G	5"	1-1/2"	\$86.
K6G	6"	2-1/2"	\$97.
K7G	7"	3-1/2"	\$108.
K8G	8"	4-1/2"	\$118.
K9G	9"	5-1/2"	\$131.
K10G	10"	6-1/2"	\$145.
K12G	12"	8-1/2"	\$168.

NYLON DESIGN - TIP INSTALLED			
Part Number	Length	Heater Width	Price Each
K5N	5"	1-1/2"	\$86.
K6N	6"	2-1/2"	\$97.
K7N	7"	3-1/2"	\$108.
K8N	8"	4-1/2"	\$118.
K9N	9"	5-1/2"	\$131.
K10N	10"	6-1/2"	\$145.
K12N	12"	8-1/2"	\$168.

FULL TAPER - TIP INSTALLED			
Part Number	Length	Heater Width	Price Each
K5T	5"	1-1/2"	\$90.
K6T	6"	2-1/2"	\$101.
K7T	7"	3-1/2"	\$112.
K8T	8"	4-1/2"	\$122.
K9T	9"	5-1/2"	\$135.
K10T	10"	6-1/2"	\$149.
K12T	12"	8-1/2"	\$172.

Kawaguchi - 1"-12, 30 x 1.5 & 38 x 3 Threads

Replacement Nozzles for Kawaguchi Type Presses.

Body with Tip Installed.

Specify To Order:

Code Number	Thread Size	Rear Opening
-1	1"-12	.625
-2	30 x 1.5	12 mm
-3	38 x 3	14 mm

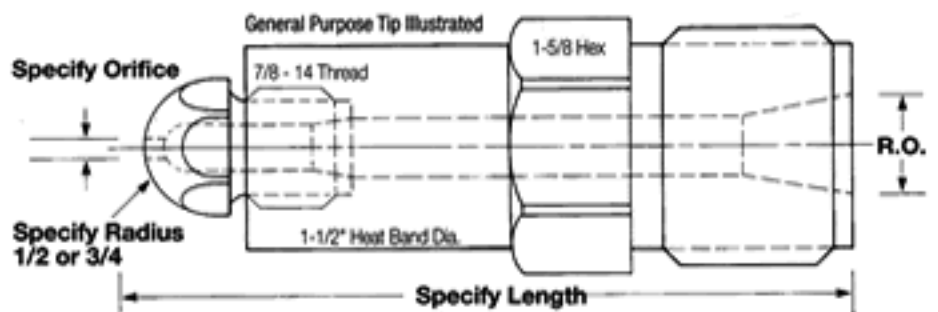

Specify: Tip Radius & Orifice
 1/8", 1/4," 10-24 or OEM Type Thermowell add \$10.00
 3/8-24 Melt Thermo or 1/2-20 Transducer Hole add \$22.00

GENERAL PURPOSE - TIP INSTALLED			
Part Number	Length	Heater Width	Price Each
KG5G	5"	2"	\$86.
KG6G	6"	3"	\$97.
KG7G	7"	4"	\$108.
KG8G	8"	5"	\$118.
KG9G	9"	6"	\$131.
KG10G	10"	7"	\$145.
KG12G	12"	9"	\$168.

NYLON DESIGN - TIP INSTALLED			
Part Number	Length	Heater Width	Price Each
KG5N	5"	2"	\$86.
KG6N	6"	3"	\$97.
KG7N	7"	4"	\$108.
KG8N	8"	5"	\$118.
KG9N	9"	6"	\$131.
KG10N	10"	7"	\$145.
KG12N	12"	9"	\$168.

FULL TAPER - TIP INSTALLED			
Part Number	Length	Heater Width	Price Each
KG5T	5"	2"	\$90.
KG6T	6"	3"	\$101.
KG7T	7"	4"	\$112.
KG8T	8"	5"	\$122.
KG9T	9"	6"	\$135.
KG10T	10"	7"	\$149.
KG12T	12"	9"	\$172.

Nissei - 35 x 2, 40 x 2 & 20 x 1.5 Threads

Replacement Nozzles for Nissei Type Presses.

Body with Tip Installed.

Specify To Order:

Code Number	Thread Size	Rear Opening
-1	20 x 1.5	8 mm
-2	35 x 2 x 37	20 mm
-3	35 x 2 x 49	20 mm
-4	40 x 2	20 mm

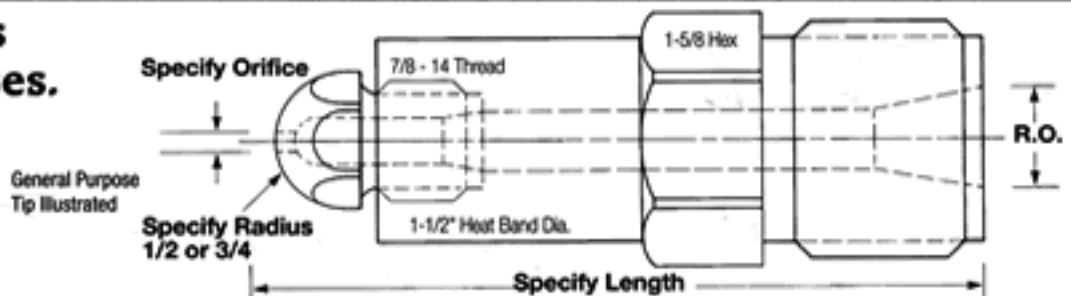

Specify: Tip Radius & Orifice
 1/8", 1/4," 10-24 or OEM Type Thermowell add \$10.00
 3/8-24 Melt Thermo or 1/2-20 Transducer Hole add \$22.00

GENERAL PURPOSE - TIP INSTALLED			
Part Number	Length	Heater Width	Price Each
NS5G	5"	C o n t a c t o r y	\$86.
NS6G	6"		\$97.
NS7G	7"		\$108.
NS8G	8"		\$118.
NS9G	9"		\$131.
NS10G	10"		\$145.
NS12G	12"		\$168.

NYLON DESIGN - TIP INSTALLED			
Part Number	Length	Heater Width	Price Each
NS5N	5"	C o n t a c t o r y	\$86.
NS6N	6"		\$97.
NS7N	7"		\$108.
NS8N	8"		\$118.
NS9N	9"		\$131.
NS10N	10"		\$145.
NS12N	12"		\$168.

FULL TAPER - TIP INSTALLED			
Part Number	Length	Heater Width	Price Each
NS5T	5"	C o n t a c t o r y	\$90.
NS6T	6"		\$101.
NS7T	7"		\$112.
NS8T	8"		\$122.
NS9T	9"		\$135.
NS10T	10"		\$149.
NS12T	12"		\$172.

HTC/TOPS-ALL Clamps, Inc.

26627 West 8 Mile Road, Redford, MI 48240 ☐ Phone: (313) 533-7500 ☐ Fax: (313) 533-1040 ☐ www.htc-topsallclamps.com

Nissei - 50 x 2 Thread

Replacement Nozzles for Nissei Type Presses.

Body with Tip Installed.



General Purpose Tip Illustrated

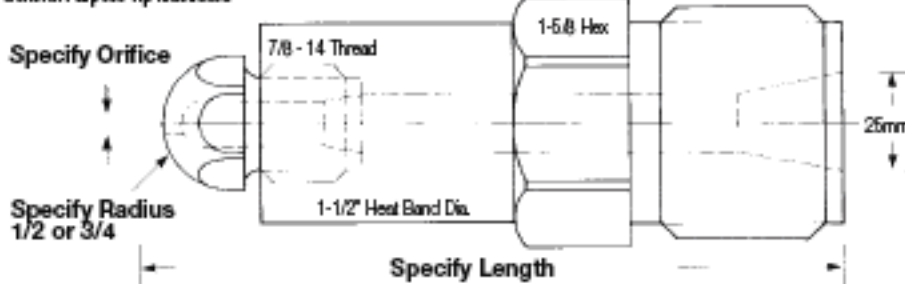

Specify: Tip Radius & Orifice

GENERAL PURPOSE - TIP INSTALLED			
Part Number	Length	Heater Width	Price Each
NIS5G	5"	1-1/2"	\$113.
NIS6G	6"	2-1/2"	\$128.
NIS7G	7"	3-1/2"	\$142.
NIS8G	8"	4-1/2"	\$157.
NIS9G	9"	5-1/2"	\$172.
NIS10G	10"	6-1/2"	\$188.
NIS12G	12"	8-1/2"	\$217.

NYLON DESIGN - TIP INSTALLED			
Part Number	Length	Heater Width	Price Each
NIS5N	5"	1-1/2"	\$113.
NIS6N	6"	2-1/2"	\$128.
NIS7N	7"	3-1/2"	\$142.
NIS8N	8"	4-1/2"	\$157.
NIS9N	9"	5-1/2"	\$172.
NIS10N	10"	6-1/2"	\$188.
NIS12N	12"	8-1/2"	\$217.

FULL TAPER - TIP INSTALLED			
Part Number	Length	Heater Width	Price Each
NIS5T	5"	1-1/2"	\$117.
NIS6T	6"	2-1/2"	\$132.
NIS7T	7"	3-1/2"	\$146.
NIS8T	8"	4-1/2"	\$161.
NIS9T	9"	5-1/2"	\$176.
NIS10T	10"	6-1/2"	\$192.
NIS12T	12"	8-1/2"	\$221.

Nissei- 50 x 12 & 60 x 2 Threads

Replacement Nozzles for Nissei Type Presses.

Body with Tip Installed.

General Purpose Tip Illustrated

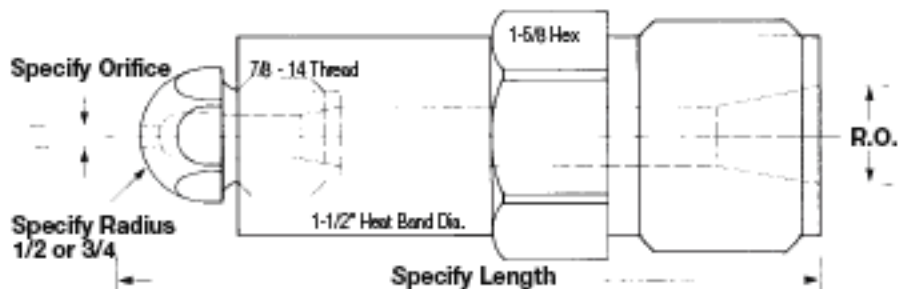

Specify To Order:

Code Number	Thread Size	Rear Opening
-1	50 x 12	26 mm
-2	60 x 2	30 mm

Specify: Tip Radius & Orifice

1/8", 1/4," 10-24 or OEM Type Thermowell add \$10.00

3/8-24 Melt Thermo or 1/2-20 Transducer Hole add \$22.00

GENERAL PURPOSE - TIP INSTALLED			
Part Number	Length	Heater Width	Price Each
NSE5G	5"	1-1/2"	\$113.
NSE6G	6"	2-1/2"	\$128.
NSE7G	7"	3-1/2"	\$142.
NSE8G	8"	4-1/2"	\$157.
NSE9G	9"	5-1/2"	\$172.
NSE10G	10"	6-1/2"	\$188.
NSE12G	12"	8-1/2"	\$217.

NYLON DESIGN - TIP INSTALLED			
Part Number	Length	Heater Width	Price Each
NSE5N	5"	1-1/2"	\$113.
NSE6N	6"	2-1/2"	\$128.
NSE7N	7"	3-1/2"	\$142.
NSE8N	8"	4-1/2"	\$157.
NSE9N	9"	5-1/2"	\$172.
NSE10N	10"	6-1/2"	\$188.
NSE12N	12"	8-1/2"	\$217.

FULL TAPER - TIP INSTALLED			
Part Number	Length	Heater Width	Price Each
NSE5T	5"	1-1/2"	\$117.
NSE6T	6"	2-1/2"	\$132.
NSE7T	7"	3-1/2"	\$146.
NSE8T	8"	4-1/2"	\$161.
NSE9T	9"	5-1/2"	\$176.
NSE10T	10"	6-1/2"	\$192.
NSE12T	12"	8-1/2"	\$221.

Nissei - 80 x 2 Thread

Replacement Nozzles for Nissei Type Presses.

Body with Tip Installed.

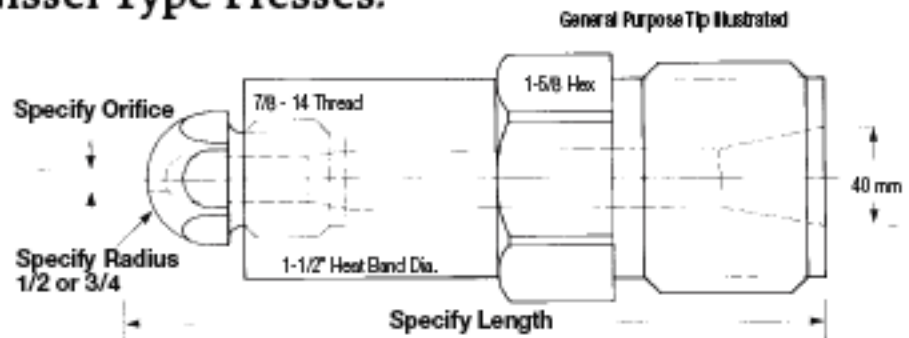

Specify: Tip Radius & Orifice

GENERAL PURPOSE - TIP INSTALLED			
Part Number	Length	Heater Width	Price Each
NSS5G	5"	N/A	\$156.
NSS6G	6"	1"	\$171.
NSS7G	7"	2"	\$186.
NSS8G	8"	3"	\$201.
NSS9G	9"	4"	\$216.
NSS10G	10"	5"	\$231.
NSS12G	12"	7"	\$261.

NYLON DESIGN - TIP INSTALLED			
Part Number	Length	Heater Width	Price Each
NSS5N	5"	N/A	\$156.
NSS6N	6"	1"	\$171.
NSS7N	7"	2"	\$186.
NSS8N	8"	3"	\$201.
NSS9N	9"	4"	\$216.
NSS10N	10"	5"	\$231.
NSS12N	12"	7"	\$261.

FULL TAPER - TIP INSTALLED			
Part Number	Length	Heater Width	Price Each
NSS5T	5"	N/A	\$160.
NSS6T	6"	1"	\$175.
NSS7T	7"	2"	\$190.
NSS8T	8"	3"	\$205.
NSS9T	9"	4"	\$220.
NSS10T	10"	5"	\$235.
NSS12T	12"	7"	\$265.

New Britain - 55 x 3 Thread

Replacement Nozzles for New Britain Type Presses.

Body with Tip Installed.

Specify To Order:

Code Number	Thread Size	Rear Opening
-1	55 mm x 3 mm	.750
-2	55 mm x 3 mm	1.25

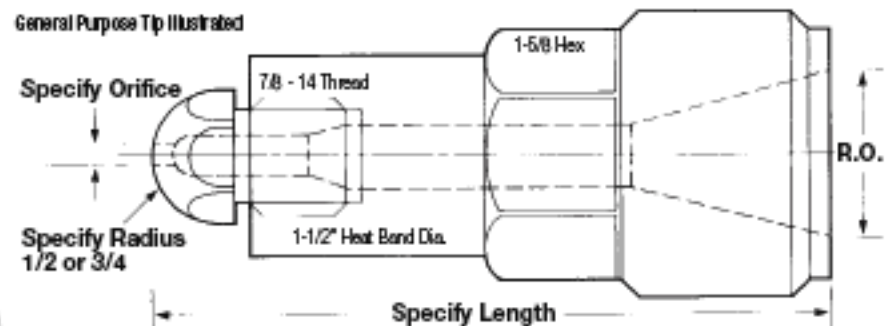

Specify: Tip Radius & Orifice

1/8", 1/4," 10-24 or OEM Type Thermowell add \$10.00
3/8-24 Melt Thermo or 1/2-20 Transducer Hole add \$22.00

GENERAL PURPOSE - TIP INSTALLED			
Part Number	Length	Heater Width	Price Each
NA5G	5"	1-3/4"	\$120.
NA6G	6"	2-3/4"	\$136.
NA7G	7"	3-3/4"	\$151.
NA8G	8"	4-3/4"	\$167.
NA10G	10"	6-3/4"	\$205.
NA12G	12"	8-3/4"	\$230.
NA18G	18"	14-3/4"	\$336.

NYLON DESIGN - TIP INSTALLED			
Part Number	Length	Heater Width	Price Each
NA5N	5"	1-3/4"	\$120.
NA6N	6"	2-3/4"	\$136.
NA7N	7"	3-3/4"	\$151.
NA8N	8"	4-3/4"	\$167.
NA10N	10"	6-3/4"	\$205.
NA12N	12"	8-3/4"	\$230.
NA18N	18"	14-3/4"	\$336.

FULL TAPER - TIP INSTALLED			
Part Number	Length	Heater Width	Price Each
NA5T	5"	1-3/4"	\$124.
NA6T	6"	2-3/4"	\$140.
NA7T	7"	3-3/4"	\$155.
NA8T	8"	4-3/4"	\$171.
NA10T	10"	6-3/4"	\$209.
NA12T	12"	8-3/4"	\$234.
NA18T	18"	14-3/4"	\$340.

HTC/TOPS-ALL Clamps, Inc.

26627 West 8 Mile Road, Redford, MI 48240 ☐ Phone: (313) 533-7500 ☐ Fax: (313) 533-1040 ☐ www.htc-topsallclamps.com

Reed Type - 1-3/4 - 8 Thread

HTC Replacement Nozzles for Beloit, Egan, Farrel, HPM, Krauss-Maffei, Lester (Late Model Presses), Lombard, Reed, Stokes, USI-Clearing, USM, IMPCO, and Cincinnati Presses manufactured 1979 and later.

Body with Tip Installed.

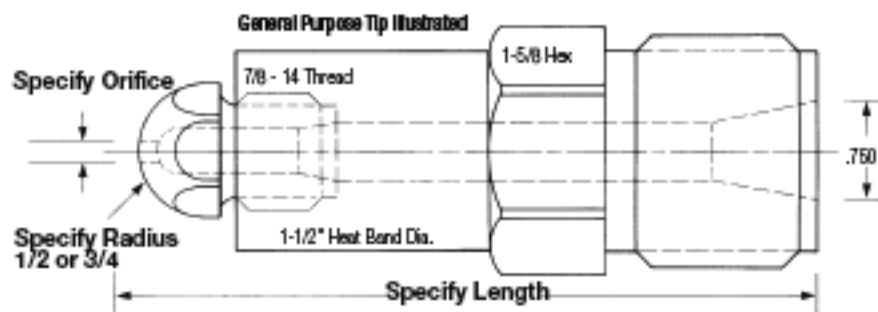

Specify: Tip Radius & Orifice
1/8 NPT, 10-24, 1/4-28 Thermowell
add \$10.00

3/8-24 Melt Thermo add \$22.00



GENERAL PURPOSE - TIP INSTALLED			
Part Number	Length	Heater Width	Price Each
R5G	5"	1-1/2"	\$81.
R6G	6"	2-1/2"	\$91.
R7G	7"	3-1/2"	\$101.
R8G	8"	4-1/2"	\$111.
R9G	9"	5-1/2"	\$123.
R10G	10"	6-1/2"	\$136.
R12G	12"	8-1/2"	\$158.
R18G	18"	11-1/2"	\$226.

NYLON DESIGN - TIP INSTALLED			
Part Number	Length	Heater Width	Price Each
R5N	5"	1-1/2"	\$81.
R6N	6"	2-1/2"	\$91.
R7N	7"	3-1/2"	\$101.
R8N	8"	4-1/2"	\$111.
R9N	9"	5-1/2"	\$123.
R10N	10"	6-1/2"	\$136.
R12N	12"	8-1/2"	\$158.
R18N	18"	11-1/2"	\$226.

FULL TAPER - TIP INSTALLED			
Part Number	Length	Heater Width	Price Each
R5T	5"	1-1/2"	\$85.
R6T	6"	2-1/2"	\$95.
R7T	7"	3-1/2"	\$105.
R8T	8"	4-1/2"	\$115.
R9T	9"	5-1/2"	\$127.
R10T	10"	6-1/2"	\$140.
R12T	12"	8-1/2"	\$162.
R18T	18"	11-1/2"	\$230.

Free Flow Full Taper Replaceable Tip Design (with identical dimensions)

Specify: Tip Radius & Orifice

FREE FLOW FULL TAPER- TIP INSTALLED			
Part Number	Length	Heater Width	Price Each
R5FT	5"	1-1/2"	\$110.
R6FT	6"	2-1/2"	\$120.
R8FT	8"	4-1/2"	\$140.
R10FT	10"	6-1/2"	\$165.
R12FT	12"	8-1/2"	\$187.

Reed Type Nozzle shown, other types also available.

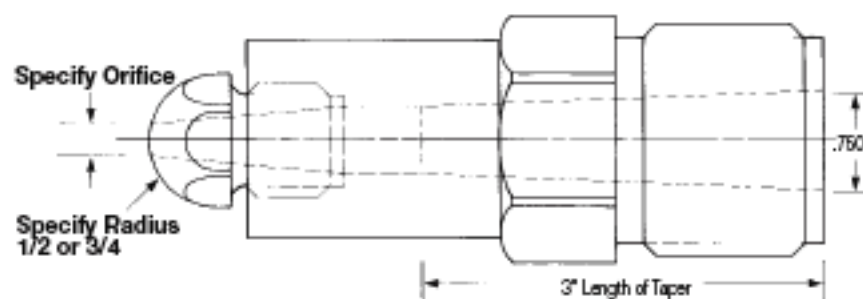

Newbury Type - 1-1/2 - 12 Thread

Replacement Nozzles for Newbury Type Presses.

Body with Tip Installed.

Specify: Tip Radius & Orifice
Newbury Type
Thermocouple Hole
add \$13.50 & Specify

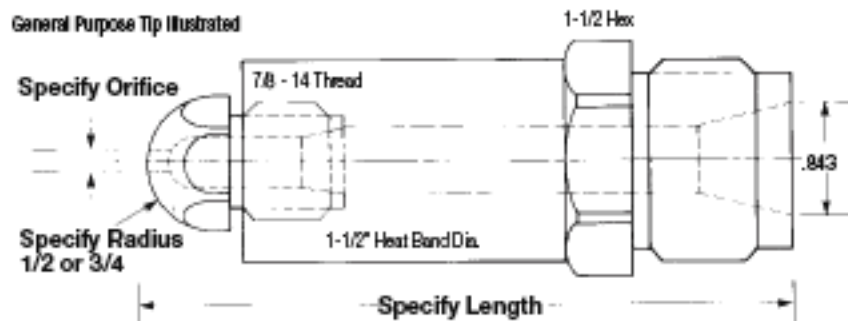

GENERAL PURPOSE - TIP INSTALLED			
Part Number	Length	Heater Width	Price Each
NBY5G	5"	2"	\$86.
NBY6G	6"	3"	\$97.
NBY7G	7"	4"	\$108.
NBY8G	8"	5"	\$118.
NBY9G	9"	6"	\$131.
NBY10G	10"	7"	\$145.
NBY12G	12"	9"	\$168.

NYLON DESIGN - TIP INSTALLED			
Part Number	Length	Heater Width	Price Each
NBY5N	5"	2"	\$86.
NBY6N	6"	3"	\$97.
NBY7N	7"	4"	\$108.
NBY8N	8"	5"	\$118.
NBY9N	9"	6"	\$131.
NBY10N	10"	7"	\$145.
NBY12N	12"	9"	\$168.

FULL TAPER - TIP INSTALLED			
Part Number	Length	Heater Width	Price Each
NBY5T	5"	2"	\$90.
NBY6T	6"	3"	\$101.
NBY7T	7"	4"	\$112.
NBY8T	8"	5"	\$122.
NBY9T	9"	6"	\$135.
NBY10T	10"	7"	\$149.
NBY12T	12"	9"	\$172.

Toshiba - 1-1/2 - 12 Thread

Replacement Nozzles for Toshiba Type Presses.

Body with Tip Installed.

Specify: Tip Radius & Orifice

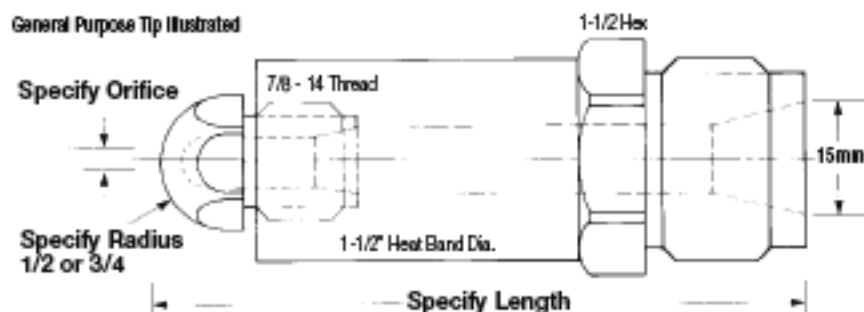

GENERAL PURPOSE - TIP INSTALLED			
Part Number	Length	Heater Width	Price Each
TO5G	5"	2"	\$86.
TO6G	6"	3"	\$97.
TO7G	7"	4"	\$108.
TO8G	8"	5"	\$118.
TO9G	9"	6"	\$131.
TO10G	10"	7"	\$145.
TO12G	12"	9"	\$168.

NYLON DESIGN - TIP INSTALLED			
Part Number	Length	Heater Width	Price Each
TO5N	5"	2"	\$86.
TO6N	6"	3"	\$97.
TO7N	7"	4"	\$108.
TO8N	8"	5"	\$118.
TO9N	9"	6"	\$131.
TO10N	10"	7"	\$145.
TO12N	12"	9"	\$168.

FULL TAPER - TIP INSTALLED			
Part Number	Length	Heater Width	Price Each
TO5T	5"	2"	\$90.
TO6T	6"	3"	\$101.
TO7T	7"	4"	\$112.
TO8T	8"	5"	\$122.
TO9T	9"	6"	\$135.
TO10T	10"	7"	\$149.
TO12T	12"	9"	\$172.

HTC/TOPS-ALL Clamps, Inc.

26627 West 8 Mile Road, Redford, MI 48240 ☐ Phone: (313) 533-7500 ☐ Fax: (313) 533-1040 ☐ www.htc-topsallclamps.com

Toshiba - 4 Sizes

Replacement Nozzles for Toshiba Type Presses.

Body with Tip Installed.

Specify To Order:

Code Number	Thread Size	Rear Opening
-1	38 x 1.5 RH	.592
-2	1-1/2 - 12	.394
-3	1-1/2 - 12	.590
-4	1-3/4-12	.500

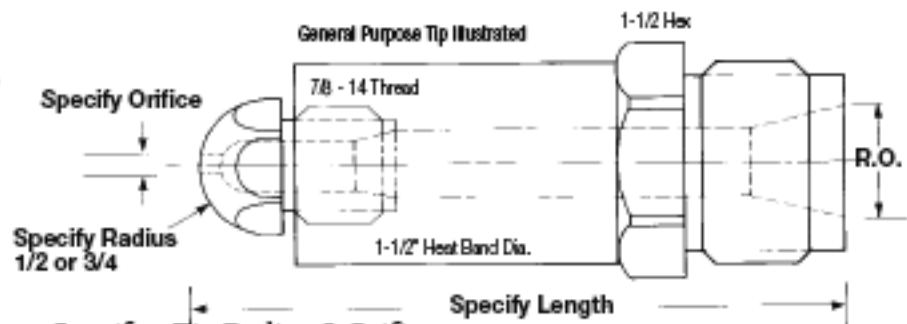

Specify: Tip Radius & Orifice
 1/8", 1/4," 10-24 or OEM Type Thermowell add \$10.00
 3/8-24 Melt Thermo or 1/2-20 Transducer Hole add \$22.00

GENERAL PURPOSE - TIP INSTALLED			
Part Number	Length	Heater Width	Price Each
TS5G	5"	2"	\$86.
TS6G	6"	3"	\$97.
TS7G	7"	4"	\$108.
TS8G	8"	5"	\$118.
TS9G	9"	6"	\$131.
TS10G	10"	7"	\$145.
TS12G	12"	9"	\$168.

NYLON DESIGN - TIP INSTALLED			
Part Number	Length	Heater Width	Price Each
TS5N	5"	2"	\$86.
TS6N	6"	3"	\$97.
TS7N	7"	4"	\$108.
TS8N	8"	5"	\$118.
TS9N	9"	6"	\$131.
TS10N	10"	7"	\$145.
TS12N	12"	9"	\$168.

FULL TAPER - TIP INSTALLED			
Part Number	Length	Heater Width	Price Each
TS5T	5"	2"	\$90.
TS6T	6"	3"	\$101.
TS7T	7"	4"	\$112.
TS8T	8"	5"	\$122.
TS9T	9"	6"	\$135.
TS10T	10"	7"	\$149.
TS12T	12"	9"	\$172.

Toshiba - 48 x 1.5 & 60 x 4 Threads

Replacement Nozzles for Toshiba Type Presses.

Body with Tip Installed.

Specify To Order:

Code Number	Thread Size	Rear Opening
-1	48 x 1.5	28 mm
-2	60 x 4	28 mm
-3	60 x 4	32 mm
-4	60 x 4	36 mm

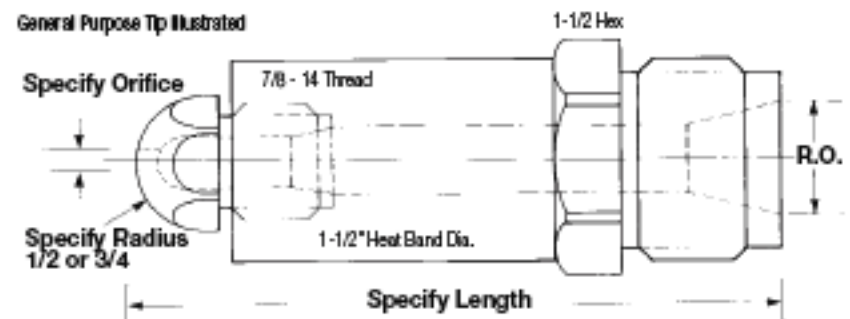

Specify: Tip Radius & Orifice
 1/8", 1/4," 10-24 or OEM Type Thermowell add \$10.00
 3/8-24 Melt Thermo or 1/2-20 Transducer Hole add \$22.00

GENERAL PURPOSE - TIP INSTALLED			
Part Number	Length	Heater Width	Price Each
TB5G	5"	C F	\$113.
TB6G	6"	o n t a c t o r y	\$128.
TB7G	7"	a c t o r y	\$142.
TB8G	8"	a c t o r y	\$157.
TB9G	9"	a c t o r y	\$172.
TB10G	10"	a c t o r y	\$188.

NYLON DESIGN - TIP INSTALLED			
Part Number	Length	Heater Width	Price Each
TB5N	5"	C F	\$113.
TB6N	6"	o n t a c t o r y	\$128.
TB7N	7"	a c t o r y	\$142.
TB8N	8"	a c t o r y	\$157.
TB9N	9"	a c t o r y	\$172.
TB10N	10"	a c t o r y	\$188.

FULL TAPER - TIP INSTALLED			
Part Number	Length	Heater Width	Price Each
TB5T	5"	C F	\$117.
TB6T	6"	o n t a c t o r y	\$132.
TB7T	7"	a c t o r y	\$146.
TB8T	8"	a c t o r y	\$161.
TB9T	9"	a c t o r y	\$176.
TB10T	10"	a c t o r y	\$192.

Toyo - 36 x 2mm or 42 x 3mm Thread

Replacement Nozzles for Toyo Type Presses.

Body with Tip Installed.

Specify: Tip Radius & Orifice

Specify To Order:

Code Number	Thread Size	Rear Opening
-1	36 x 2	23 mm
-2	42 x 3	24 mm

General Purpose Tip Illustrated

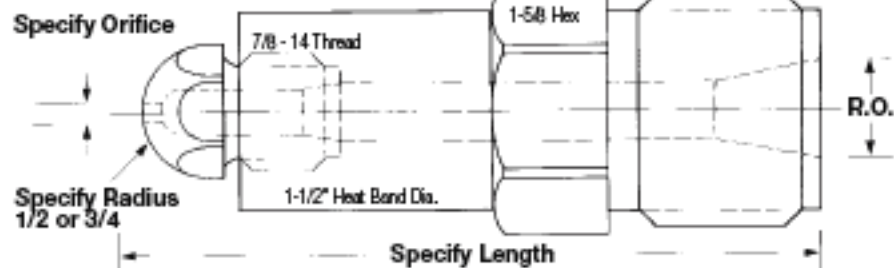

GENERAL PURPOSE - TIP INSTALLED			
Part Number	Length	Heater Width	Price Each
TY5G	5"	2"	\$107.
TY6G	6"	3"	\$117.
TY7G	7"	4"	\$127.
TY8G	8"	5"	\$137.
TY9G	9"	6"	\$147.
TY10G	10"	7"	\$157.
TY12G	12"	9"	\$177.

NYLON DESIGN - TIP INSTALLED			
Part Number	Length	Heater Width	Price Each
TY5N	5"	2"	\$107.
TY6N	6"	3"	\$117.
TY7N	7"	4"	\$127.
TY8N	8"	5"	\$137.
TY9N	9"	6"	\$147.
TY10N	10"	7"	\$157.
TY12N	12"	9"	\$177.

FULL TAPER - TIP INSTALLED			
Part Number	Length	Heater Width	Price Each
TY5T	5"	2"	\$111.
TY6T	6"	3"	\$121.
TY7T	7"	4"	\$131.
TY8T	8"	5"	\$141.
TY9T	9"	6"	\$151.
TY10T	10"	7"	\$161.
TY12T	12"	9"	\$181.

Toyo - 50 x 3mm Thread

Replacement Nozzles for Toyo Type Presses.

Body with Tip Installed.



General Purpose Tip Illustrated

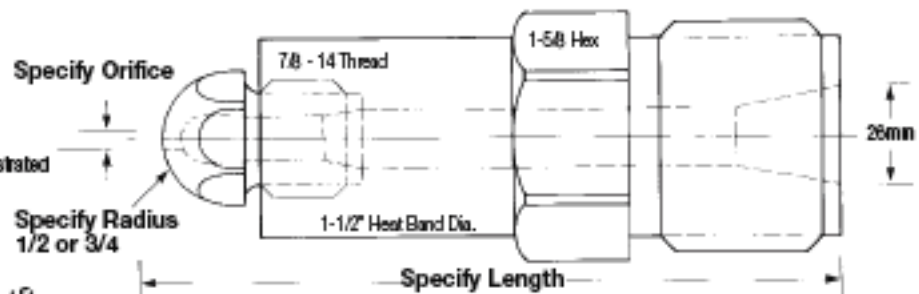

Specify: Tip Radius & Orifice

1/8", 1/4", 10-24 or OEM Type Thermowell add \$10.00

3/8-24 Melt Thermo or 1/2-20 Transducer Hole add \$22.00

GENERAL PURPOSE - TIP INSTALLED			
Part Number	Length	Heater Width	Price Each
T5G	5"	1"	\$136.
T6G	6"	2"	\$146.
T7G	7"	3"	\$156.
T8G	8"	4"	\$166.
T9G	9"	5"	\$176.
T10G	10"	6"	\$186.
T12G	12"	8"	\$206.

NYLON DESIGN - TIP INSTALLED			
Part Number	Length	Heater Width	Price Each
T5N	5"	1"	\$136.
T6N	6"	2"	\$146.
T7N	7"	3"	\$156.
T8N	8"	4"	\$166.
T9N	9"	5"	\$176.
T10N	10"	6"	\$186.
T12N	12"	8"	\$206.

FULL TAPER - TIP INSTALLED			
Part Number	Length	Heater Width	Price Each
T5T	5"	1"	\$140.
T6T	6"	2"	\$150.
T7T	7"	3"	\$160.
T8T	8"	4"	\$170.
T9T	9"	5"	\$180.
T10T	10"	6"	\$190.
T12T	12"	8"	\$210.

HTC/TOPS-ALL Clamps, Inc.

26627 West 8 Mile Road, Redford, MI 48240 ☐ Phone: (313) 533-7500 ☐ Fax: (313) 533-1040 ☐ www.htc-topsallclamps.com

Van Dorn Type - 1-3/4 - 8 Thread

Replacement Nozzles for Van Dorn Type Presses.

Body with Tip Installed.

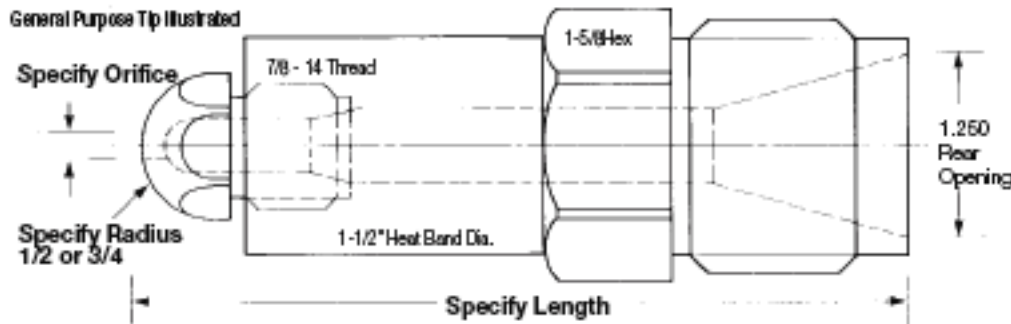

Specify: Tip Radius & Orifice

1/8", 1/4", 10-24 or OEM Type Thermowell add \$10.00

3/8-24 Melt Thermo or 1/2-20 Transducer Hole \$22.00

GENERAL PURPOSE - TIP INSTALLED			
Part Number	Length	Heater Width	Price Each
V5G	5"	1-1/2"	\$86.
V6G	6"	2-1/2"	\$96.
V7G	7"	3-1/2"	\$106.
V8G	8"	4-1/2"	\$116.
V9G	9"	5-1/2"	\$128.
V10G	10"	6-1/2"	\$141.
V12G	12"	8-1/2"	\$163.
V18G	18"	14-1/2"	\$231.

NYLON DESIGN - TIP INSTALLED			
Part Number	Length	Heater Width	Price Each
V5N	5"	1-1/2"	\$86.
V6N	6"	2-1/2"	\$96.
V7N	7"	3-1/2"	\$106.
V8N	8"	4-1/2"	\$116.
V9N	9"	5-1/2"	\$128.
V10N	10"	6-1/2"	\$141.
V12N	12"	8-1/2"	\$163.
V18N	18"	14-1/2"	\$231.

FULL TAPER - TIP INSTALLED			
Part Number	Length	Heater Width	Price Each
V5T	5"	1-1/2"	\$90.
V6T	6"	2-1/2"	\$100.
V7T	7"	3-1/2"	\$110.
V8T	8"	4-1/2"	\$120.
V9T	9"	5-1/2"	\$132.
V10T	10"	6-1/2"	\$145.
V12T	12"	8-1/2"	\$167.
V18T	18"	14-1/2"	\$235.

Free Flow Full Taper Replaceable Tip Design (with identical dimensions)

Specify: Tip Radius & Orifice

Van Dorn Type Nozzle shown, other types also available.

FREE FLOW FULL TAPER - TIP INSTALLED			
Part Number	Length	Heater Width	Price Each
V5FT	5"	1-1/2"	\$110.
V6FT	6"	2-1/2"	\$120.
V8FT	8"	4-1/2"	\$140.
V10FT	10"	6-1/2"	\$165.
V12FT	12"	8-1/2"	\$187.

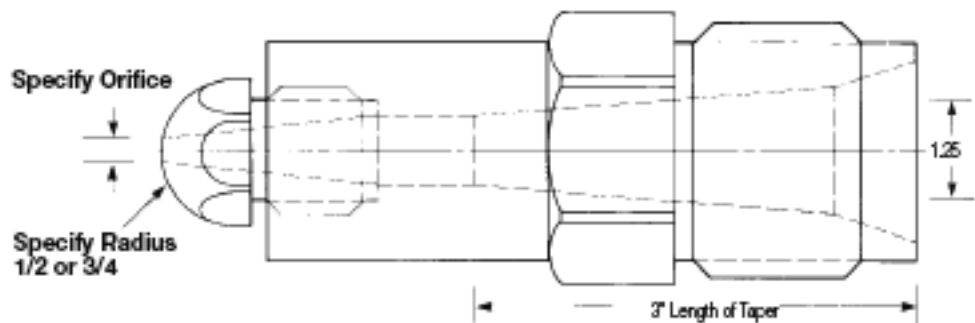

Van Dorn & Beloit Type - 1-1/4 - 12 Thread

Replacement Nozzles for Van Dorn & Beloit Type Presses.

Body with Tip Installed.



General Purpose Tip Illustrated

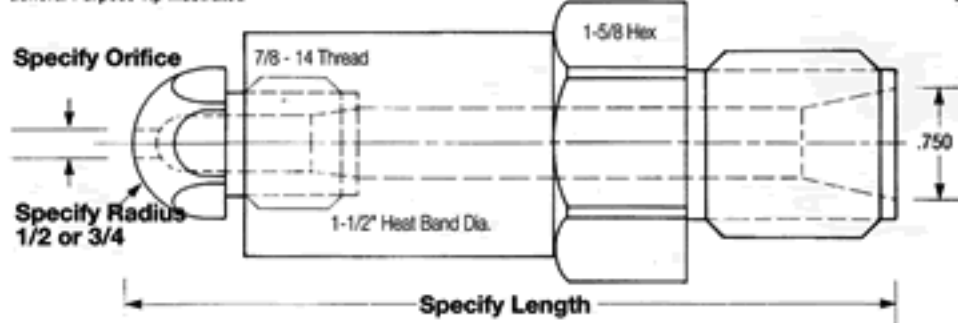

Specify: Tip Radius & Orifice

1/8", 1/4", 10-24 or OEM Type Thermowell add \$10.00

3/8-24 Melt Thermo or 1/2-20 Transducer Hole \$22.00

GENERAL PURPOSE - TIP INSTALLED			
Part Number	Length	Heater Width	Price Each
VD5G	5"	2"	\$81.
VD6G	6"	3"	\$91.
VD7G	7"	4"	\$101.
VD8G	8"	5"	\$111.
VD9G	9"	6"	\$123.
VD10G	10"	7"	\$136.
VD12G	12"	9"	\$158.
VD18G	18"	15"	\$226.

NYLON DESIGN - TIP INSTALLED			
Part Number	Length	Heater Width	Price Each
VD5N	5"	2"	\$81.
VD6N	6"	3"	\$91.
VD7N	7"	4"	\$101.
VD8N	8"	5"	\$111.
VD9N	9"	6"	\$123.
VD10N	10"	7"	\$136.
VD12N	12"	9"	\$158.
VD18N	18"	15"	\$226.

FULL TAPER - TIP INSTALLED			
Part Number	Length	Heater Width	Price Each
VD5T	5"	2"	\$85.
VD6T	6"	3"	\$95.
VD7T	7"	4"	\$105.
VD8T	8"	5"	\$115.
VD9T	9"	6"	\$127.
VD10T	10"	7"	\$140.
VD12T	12"	9"	\$162.
VD18T	18"	15"	\$230.

Free Flow Full Taper Replaceable Tip Design (with identical dimensions)

Specify: Tip Radius & Orifice

Van Dorn Type Nozzle shown, other types also available.

FREE FLOW FULL TAPER - TIP INSTALLED			
Part Number	Length	Heater Width	Price Each
VD5FT	5"	2"	\$110.
VD6FT	6"	3"	\$120.
VD8FT	8"	5"	\$140.
VD10FT	10"	7"	\$165.
VD12FT	12"	9"	\$187.

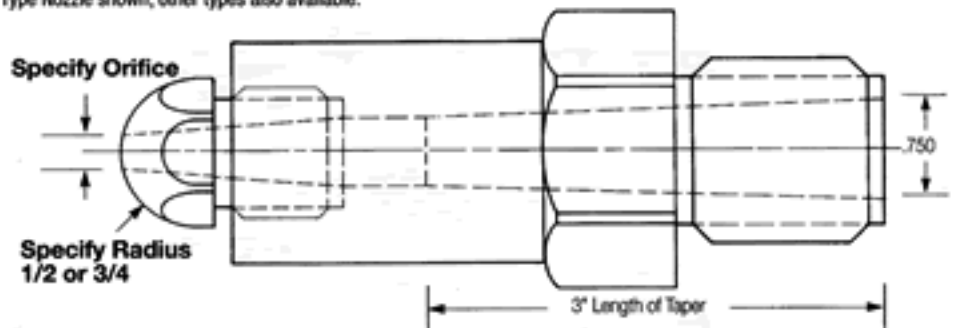

HTC/TOPS-ALL Clamps, Inc.

26627 West 8 Mile Road, Redford, MI 48240 ☐ Phone: (313) 533-7500 ☐ Fax: (313) 533-1040 ☐ www.htc-topsallclamps.com

Nozzle Heater Bands

- MICA Insulated
- 12" Flexible Leads
- 220 - 240 Voltage

**New
Lower
Prices**



HEATER BANDS V or R NOZZLE LENGTHS		
Nozzle Length V or R	Heater Band Size	Heater Band Price
5"	1-1/2" x 1-1/2"	\$11.00
6"	1-1/2" x 2"	\$11.00
7"	1-1/2" x 3"	\$11.50
8"	1-1/2" x 4"	\$12.00
9"	1-1/2" x 5"	\$13.00
10"	1-1/2" x 6"	\$21.50
12"	(2) 1-1/2" x 4"	\$24.00

HEATER BANDS VD or NBY NOZZLE LENGTHS		
Nozzle Length VD or NBY	Heater Band Size	Heater Band Price
5"	1-1/2" x 2"	\$11.00
6"	1-1/2" x 3"	\$11.50
7"	1-1/2" x 4"	\$12.00
8"	1-1/2" x 5"	\$13.00
9"	1-1/2" x 6"	\$21.50

HEATER BANDS FOR EXTENSION TIPS		
Extension Tip Number	Heater Band Size	Heater Band Price
RTX-GR	1" x 1"	\$10.00
RTX-GR4	1" x 2"	\$10.00
RTX-GR5	1" x 3"	\$11.00
RTX-GR6	1" x 4"	\$11.00
RTX-GR8	(2) 1" x 3"	\$22.00
ADAPTOR	2-1/2" x 1-1/2"	\$12.00

110 Volt available upon request

Internal Heat Installation

(For all HTC Manufactured Nozzles)

**Replaceable Tips, or Solid Type,
Requires 1-5/8 Minimum
Clearance Diameter**

To order, add I-H to selected Part Number

Add on cost includes 3 equally spaced 1/4" diameter
cartridge heaters installed, 220-240 volt standard.

Specify To Order:

Nozzle Length	Add on Nozzle Cost	Cartridge Length	Watts	Cartridge Replacement Cost
5"	\$141.00	1-1/2"	150	\$20.00
6"	\$157.00	2"	200/300	\$19.50
7"	\$169.00	3"	125/200	\$21.00
8"	\$191.00	4"	300	\$23.50
9"	\$213.00	5"	330	\$26.00
10"	\$235.00	6"	200/400	\$28.50
12"	\$278.00	8"	200/400	\$32.50



Ring Check Valves - (assembled)

See page 20 for
Product Information.

Part No.	Size Dia.	Price Each
BELOIT		
BL175	1-3/4"	\$400.
BL212	2-1/8"	\$465.
BL250	2-1/2"	\$500.

BOY		
B24	24mm	\$325.
B35	35mm	\$345.

CINCINNATI		
C22	22mm	\$285.
C24	24mm	\$310.
C28	28mm	\$325.
C35	35mm	\$360.
C40	40mm	\$400.
C45	45mm	\$430.
C50	50mm	\$485.
C55	55mm	\$565.
C65	65mm	\$650.
C70	70mm	\$800.
C131	1-5/16"	\$325.
C162	1-5/8"	\$370.
C175	1-3/4"	\$400.
C200	2"	\$435.
C225	2-1/4"	\$465.
C250	2-1/2"	\$500.
C275	2-3/4"	\$590.
C325	3-1/4"	\$695.
C350	3-1/2"	\$850.
C450	4-1/2"	\$1030.
C525	5-1/4"	\$1390.
C600	6"	\$1640.

EGAN		
E250	2-1/2"	\$500.
E300	3"	\$675.
E350	3-1/2"	\$800.
E400	4"	\$900.
E450	4-1/2"	\$1030.
E525	5-1/4"	\$1390.

ENGEL		
EN22	22mm	\$285.
EN35	35mm	\$360.
EN45	45mm	\$445.
EN55	55mm	\$565.
EN70	70mm	\$750.
EN80	80mm	\$860.

FARREL		
F162	1-5/8"	\$370.
F200	2"	\$435.
F210	2.1	\$445.
F250	2-1/2"	\$500.
F300	3"	\$675.
F325	3-1/4"	\$695.
F360	3.6	\$850.
F425	4-1/4"	\$970.
F450	4-1/2"	\$1030.
F525	5-1/4"	\$1390.

FELLOWS		
FL200	2"	\$435.
FL250	2-1/2"	\$500.
FL350	3-1/2"	\$850.

H.P.M.		
H137	1-3/8"	\$350.
H150	1-1/2"	\$360.
H175	1-3/4"	\$400.
H200	2"	\$435.
H250	2-1/2"	\$500.
H300	3"	\$675.
H350	3-1/2"	\$850.
H400	4"	\$900.
H450	4-1/2"	\$1030.
H525	5-1/4"	\$1390.
H600	6"	\$1735.

J.S.W.		
J40	40mm	\$395.

KAWAGUCHI		
K34	34mm	\$345.
K36	36mm	\$345.
K40	40mm	\$395.
K42	42mm	\$395.
K45	44mm	\$430.
K55	55mm	\$465.
K60	60mm	\$595.

LOMBARD		
L300	3"	\$675.
L350	3-1/2"	\$850.

MIR		
M150	1-1/2"	\$360.

NANRONG		
NN60	60mm	\$605.
NN65	65mm	\$650.

NATCO		
N45	45mm	\$445.
N225	2-1/4"	\$565.
N90	90mm	\$985.
N120	120mm	\$1195.
N135	135mm	\$1320.

NISSEI		
NE19	19mm	\$260.
NE22	22mm	\$285.
NE26	26mm	\$290.
NE28	28mm	\$325.
NE30	30mm	\$360.
NE36	36mm	\$375.
NE38	38mm	\$385.
NE48	48mm	\$470.
NE75	75mm	\$705.

NEW BRITAIN		
NA30	30mm	\$340.
NA36	36mm	\$375.
NA42	42mm	\$385.
NA45	45mm	\$450.
NA55	55mm	\$520.
NA162	1-5/8"	\$370.
NA250	2-1/2"	\$500.

NEWBURY		
NB100	1"	\$310.
NB137	1-3/8"	\$340.
NB200	2"	\$430.
NB225	2-1/4"	\$465.

REED		
R162	1-5/8"	\$375.
R200	2"	\$435.
R212	2-1/8"	\$465.
R250	2-1/2"	\$500.
R300	3"	\$675.
R337	3-3/8"	\$785.
R375	3-3/4"	\$890.

STOKES		
S125	1-1/4"	\$325.
S137	1-3/8"	\$340.
S162	1-5/8"	\$370.
S187	1-7/8"	\$415.
S200	2"	\$435.
S250	2-1/2"	\$500.

T.M.C.		
TMC35	35mm	\$345.
TMC40	40mm	\$395.
TMC50	50mm	\$485.
TMC55	55mm	\$565.

TOSHIBA		
T32	32mm	\$340.
T36	36mm	\$375.
T40	40mm	\$400.
T50	50mm	\$485.
T55	55mm	\$565.
T60	60mm	\$605.
T70	70mm	\$800.
T80	80mm	\$900.

TOYO		
TY28	28mm	\$310.
TY32	32mm	\$340.
TY40	40mm	\$400.
TY50	50mm	\$485.
TY68	68mm	\$750.

VAN DORN		
V22	22mm	\$280.
V28	28mm	\$310.
V30	30mm	\$315.
V35	35mm	\$345.
V38	38mm	\$365.
V40	40mm	\$395.
V50	50mm	\$485.
V57	57mm	\$565.
V65	65mm	\$650.
V69	69mm	\$750.
V75	75mm	\$825.
V80	80mm	\$860.
V90	90mm	\$990.
V105	105mm	\$1090.
V115	115mm	\$1250.
V135	135mm	\$1450.
V150	150mm	\$1735.

TRUBOR		
TB28	28mm	\$310.
TB31	31mm	\$315.
TB35	35mm	\$345.
TB41	41mm	\$400.

WINDSOR		
W42	42mm	\$385.

If you don't see the screw tip you're looking for, send us a sample or a print and we will make it for you in 7-10 days.

HTC/TOPS-ALL Clamps, Inc.

26627 West 8 Mile Road, Redford, MI 48240 ☐ Phone: (313) 533-7500 ☐ Fax: (313) 533-1040 ☐ www.htc-topsallclamps.com

Ring Check Valves

See page 19 for
a Partial Product Listing.

Retainer - High Speed Composite Construction for Maximum Wear and Torque Resistance. Check Ring and Seat - D2.

HTC/TOPS-ALL is presently producing a longer wearing, fatigue and shock resistant *Ring Check Valve* utilizing Composite Construction.

The Retainer (screw tip) is manufactured of alloy steel of high tensile and yield, properties essential to prevent breakage.

To increase wearability, the High Speed Composite is weld bonded to the Retainer's angular check surface.

D-2 Tool Steel provides dissimilar wear hardness surfaces for the Check Ring and Seat.



Other sizes available upon request!!

Nozzle Thread/Metal Filter Adaptors

- Use Standard 1-3/4 - 8 Threads for Odd Size Nozzles.
- Lower Cost, Off-the-Shelf Nozzle Replacements.
- Longer Lengths for Deep Cavity Molding.
- Precision Machined, Yet Low Priced.



See page 21 for prices and a partial listing of available sizes.

Other sizes available upon request!!

Nozzle Tip Adaptors for Small Presses

Install permanently to utilize standard 7/8-14 Thread Replaceable Nozzle Tips and Extension Tips (1-1/2 through 8" in Stock). Specify: Press, Male Thread Size, and Rear Opening (Toyo 24mm Adaptor Illustrated)

Thread sizes less than 49mm - \$50.00

Thread sizes 50mm thru 65mm - \$75.00

Thread sizes 66mm and up - \$90.00

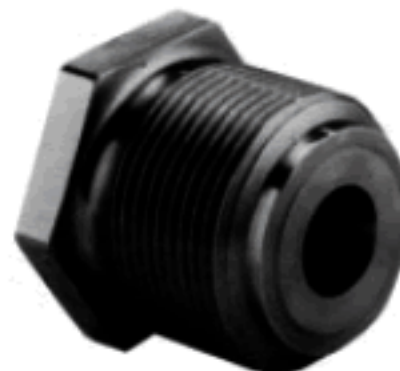

Other sizes available upon request!!

Nozzle Thread Adaptors

Thread Size	Rear Opening	Price Each	Thread Size	Rear Opening	Price Each	Thread Size	Rear Opening	Price Each	Thread Size	Rear Opening	Price Each
ARBURG			CINCINNATI			JSW			SANDRETTO		
24 x 1.5LH	8mm	\$175.	1-1/2-12	.500	\$175.	1.945 x 3	15mm	\$175.	55 x 3	1.589	\$145.
24 x 1.5RH	8mm	\$175.	1-1/4-12	.743	\$175.	44 x 3	20mm	\$145.	50 x 3	35mm	\$145.
35 x 2LH	19mm	\$145.	1-1/2-12	.830	\$175.	50 x 3	.590	\$175.	STOKES		
35 x 2RH	19mm	\$145.	1-3/4-8	.750	\$145.	55 x 3	8mm	\$175.	1-3/4-8	1.250	\$145.
39 x 2LH	Advise	\$145.	2"-8	1.000	\$145.	55 x 3	.500	\$175.	1-3/4-8	1.375	\$145.
45 x 1.5RH	22mm	\$145.	DEMAG			KAWAGUCHI			TMC		
45 x 1.5LH	22mm	\$145.	45 x 3	25mm	\$145.	1"-12	.625	\$175.	32 x 2	.750	\$145.
45 x 1.5LH	25mm	\$145.	60 x 3	25mm	\$145.	1-1/4-12	.937	\$145.	52 x 3	.873	\$145.
45 x 1.5LH	30mm	\$145.	60 x 2	31mm	\$145.	1-1/4-12	.875	\$145.	52 x 3	15mm	\$175.
45 x 2LH	18mm	\$175.	ENGEL			MITSUBISHI			TOSHIBA		
45 x 2LH	22mm	\$145.	1-1/4-10	.750	\$145.	1-3/4-8	.937	\$145.	1-1/2-12	.590	\$175.
45 x 2LH	25mm	\$145.	32 x 2.5	20mm	\$145.	30 x 1.5	12mm	\$175.	1-1/2-12	15mm	\$175.
45 x 2LH	30mm	\$145.	40 x 3	30mm	\$145.	30 x 3	.500	\$175.	38 x 1.5	.592	\$175.
50 x 2	30mm	\$145.	45 x 3	1.250	\$145.	38 x 3	.560	\$175.	48 x 1.5	28mm	\$145.
50 x 2	35mm	\$145.	FARREL			MIR			1-3/4-12	.500	\$175.
52 x 2	30mm	\$145.	1-3/4-8	.500	\$175.	1-1/2-12	.600	\$175.	60 x 4	28mm	\$145.
52 x 2	35mm	\$145.	1-3/4-8	1.000	\$145.	1-1/2-12RH	.925	\$145.	60 x 4	32mm	\$145.
52 x 2LH	35mm	\$145.	FELLOWS			NATCO			60 x 4	36mm	\$145.
52 x 2LH	40mm	\$145.	1-1/4-10	.750	\$145.	1-1/4-8 female	.600	\$175.	60 x 4	52mm	\$145.
55 x 2	30mm	\$145.	1-3/4-12	.750	\$145.	3"-8	1.750	\$145.	3-1/4-8	2.04	\$145.
55 x 2LH	30mm	\$145.	HPM			NEW BRITAIN			TOYO		
55 x 2	40mm	\$145.	1-5/8-12 female	.500	\$175.	55 x 3	.750	\$145.	36 x 2	23mm	\$145.
60 x 2	45mm	\$145.	1-5/8-12 female	.750	\$145.	55 x 3	1.300	\$145.	42 x 3	24mm	\$145.
AUTOJECTOR			1-3/4-8	1.000	\$145.	NEWBURY			50 x 3	26mm	\$145.
1-1/2-12	1.000	\$145.	HUSKY			NISSEI			TRUBOR		
1-3/4-12	.780	\$145.	1-3/4-8	1.000	\$145.	20 x 1.5	8mm	\$175.	1-3/4-8	.882	\$145.
1-3/4-12	1.250	\$145.	45 x 3	16mm	\$175.	35 x 2	20mm	\$145.	1-3/4-8	25mm	\$145.
2"-12	1.500	\$145.	45 x 3	22mm	\$145.	40 x 2	.787	\$145.	1-3/4-8	28mm	\$145.
BATTENFELD			64 x 4	16mm	\$175.	50 x 2	1.023	\$145.	1-3/4-8	31mm	\$145.
35 x 2	25mm	\$145.	72 x 4	16mm	\$175.	50 x 12	26mm	\$145.	2"-8	35mm	\$145.
40 x 2	25mm	\$145.	IMPCO			60 x 2	30mm	\$145.	2"-8	38mm	\$145.
40 x 2	30mm	\$145.	1-1/4-12	.750	\$145.	80 x 2	40mm	\$145.	2-1/4-8	41mm	\$145.
45 x 2	35mm	\$145.	1-3/4-12	.750	\$145.	VAN DORN					
35 x 2	21mm	\$145.									
TR65 x 3	48mm	\$145.									
TR90x 4	48mm	\$145.									
BOY											
24 x 1.5	14mm	\$175.									
33 x 1.5	22mm	\$145.									
33 x 1.5	16mm	\$175.									
35 x 1.5	22mm	\$145.									
35 x 1.5	16mm	\$175.									

Other sizes available upon request!!

Metal Filter Adaptors

Adaptor - \$185. Filter Pack - \$85. Assembly - \$270.
Specify Thread Size and Name of Press

HTC/TOPS-ALL Clamps, Inc.

26627 West 8 Mile Road, Redford, MI 48240 ☐ Phone: (313) 533-7500 ☐ Fax: (313) 533-1040 ☐ www.htc-topsallclamps.com

Specialized Parts Made To Order

HTC/TOPS-ALL Clamps, Inc. is a complete machine shop. Our capabilities are extensive with high standards and quality workmanship.

If you need a part not found in our catalog, provide us with a sketch or sample of your part. We will be happy to quote the part at a competitive price and exceptional delivery.



ADAPTOR*

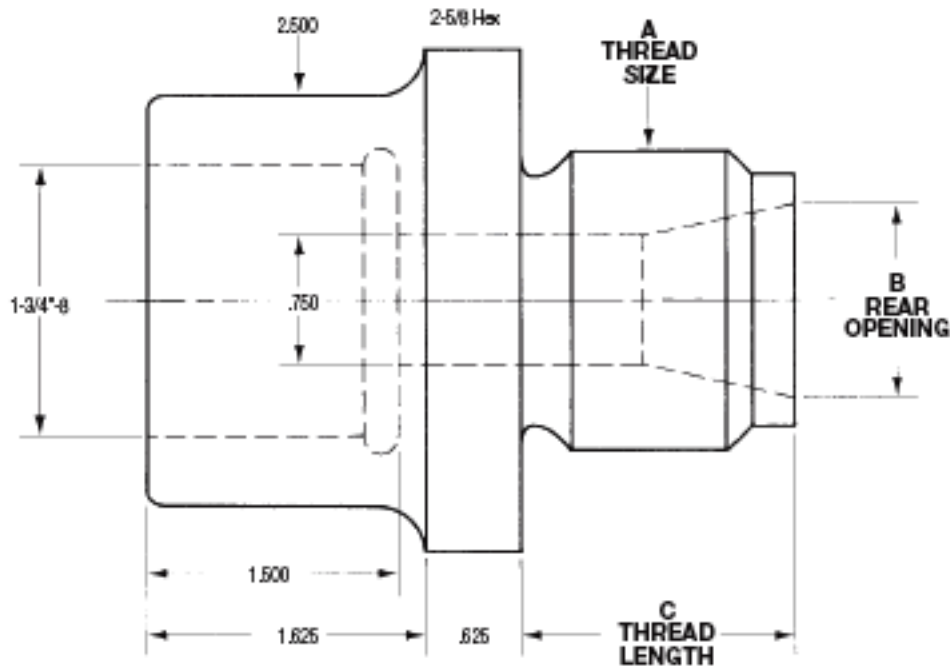

NOZZLE*

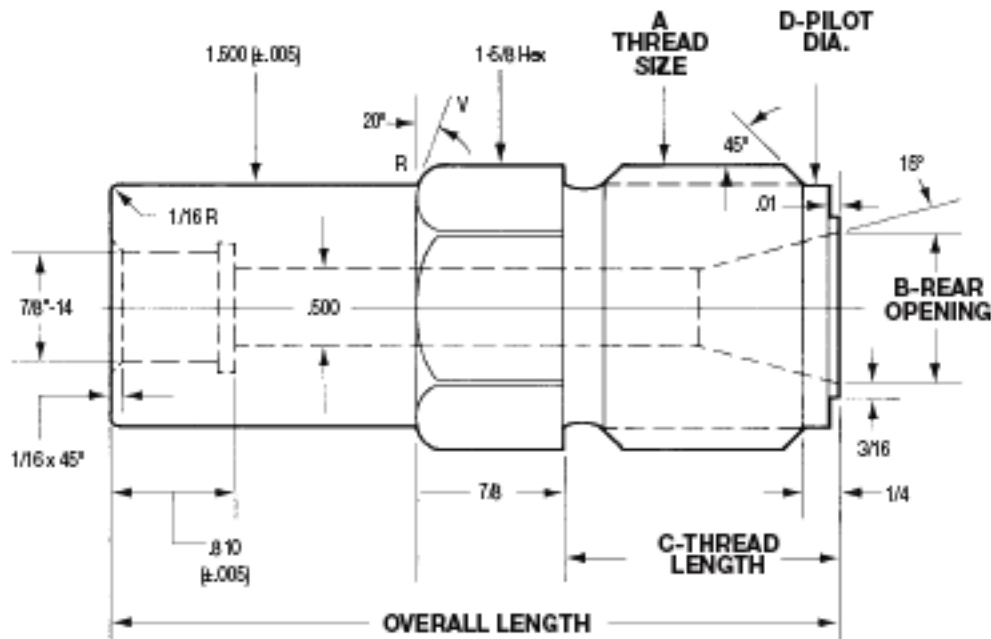

* FILL IN THE APPROPRIATE DIMENSIONS AND FAX US FOR 24-HOUR DELIVERY (IN MOST CASES).

Open Slot Style Mold Clamp Assemblies

Heavy Duty
(with Swivel-Base Adjusting Screw)



Each Mold
Clamp Assembly
Consists of...

- 1-Mold Clamp Body
- 1-Clamp Adjusting
Screw
- 1-Mold Washer
- 1-Clamping Screw

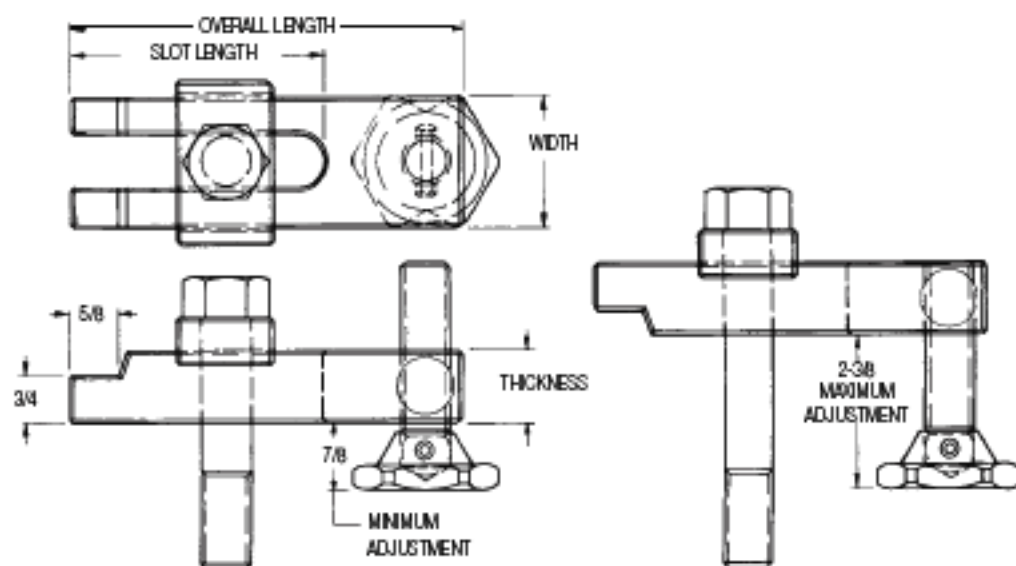

For Clamping Screw Diameter	Clamping Screw Size Supplied With Assembly Diameter x Length	Mold Clamp Body Specifications				Complete Assembly Part Number	Price Each	Individual Clamp Bodies Part Number	Price Each
		Thickness	Width	Slot Length	Overall Length				
5/8	5/8-11 x 3-1/2	1"	1-3/4	2-3/4	4	TAC-584-A	\$29.00	HD-584	\$15.75
				3-1/4	5	TAC-585-A	\$30.75	HD-585	\$17.50
				3-3/4	6	TAC-586-A	\$32.75	HD-586	\$19.50
				4-1/4	7	TAC-587-A	\$34.25	HD-587	\$21.50
3/4	3/4-10 x 4	1-1/8	2	3-3/8	5	TAC-755-A	\$37.25	HD-755	\$21.75
				3-7/8	6	TAC-756-A	\$39.25	HD-756	\$23.75
				4-3/8	7	TAC-757-A	\$41.25	HD-757	\$25.75
				5-3/8	8	TAC-758-A	\$43.50	HD-758	\$28.00
1"	1"-8 x 5	1-1/2	2-1/2	6	10	TAC-110-A	\$66.00	HD-110	\$38.25

HTC/TOPS-ALL Clamps, Inc.

26627 West 8 Mile Road, Redford, MI 48240 ☐ Phone: (313) 533-7500 ☐ Fax: (313) 533-1040 ☐ www.htc-topsallclamps.com

Open Slot Style Mold Clamp Assemblies

Extra Heavy Duty
(with Swivel-Base Adjusting Screw)

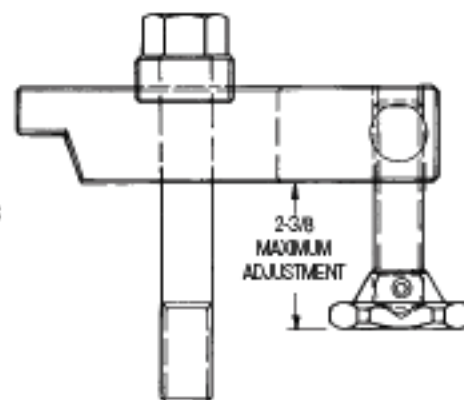
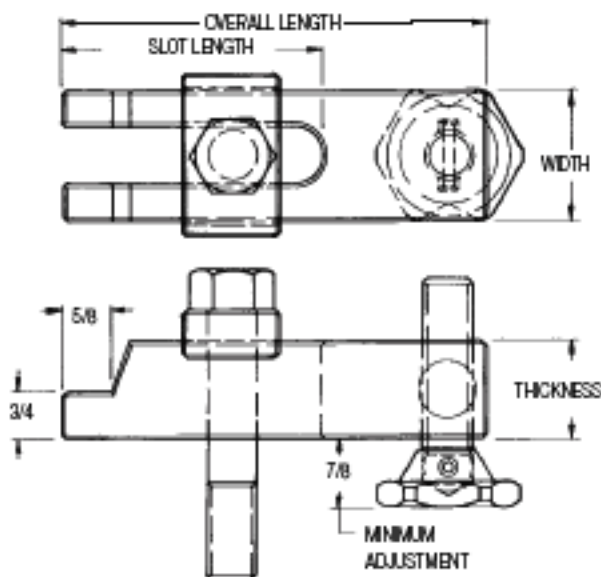

For Clamping Screw Diameter	Clamping Screw Size Supplied With Assembly Diameter x Length	Mold Clamp Body Specifications				Complete Assembly Part Number	Price Each	Individual Clamp Bodies Part Number	Price Each
		Thickness	Width	Slot Length	Overall Length				
5/8	5/8-11 x 3-3/4	1-1/4	1-3/4	3-5/8	6	TAC-5860-A	\$36.00	XHD-5860	\$23.25
				4-5/8	7-1/2	TAC-5875-A	\$39.25	XHD-5875	\$26.25
3/4	3/4-10 x 4-1/2	1-1/2	2	4	6-1/2	TAC-7565-A	\$49.00	XHD-7565	\$33.25
				5	8	TAC-7580-A	\$52.00	XHD-7580	\$36.25
				6	9-1/2	TAC-7595-A	\$55.50	XHD-7595	\$39.25
1"	1"-8 x 5-1/2	1-3/4	2-1/2	4-3/8	8	TAC-1008-A	\$70.50	XHD-1008	\$41.50
				6-3/8	11	TAC-1011-A	\$77.00	XHD-1011	\$49.50

Enclosed Slot Style Clamp Assemblies

Extra Heavy Duty
(with Swivel-Base Adjusting Screw)

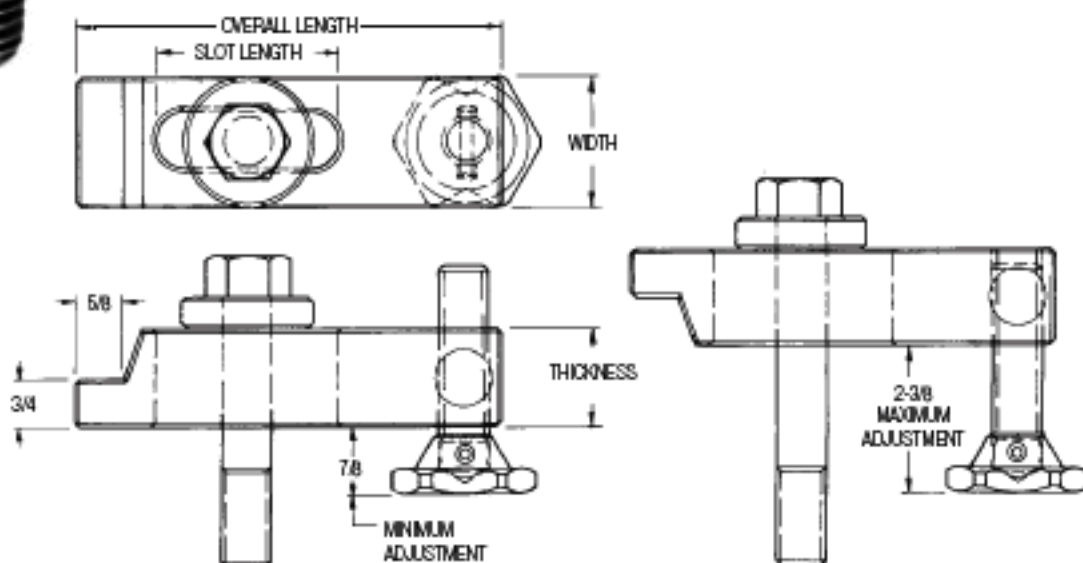
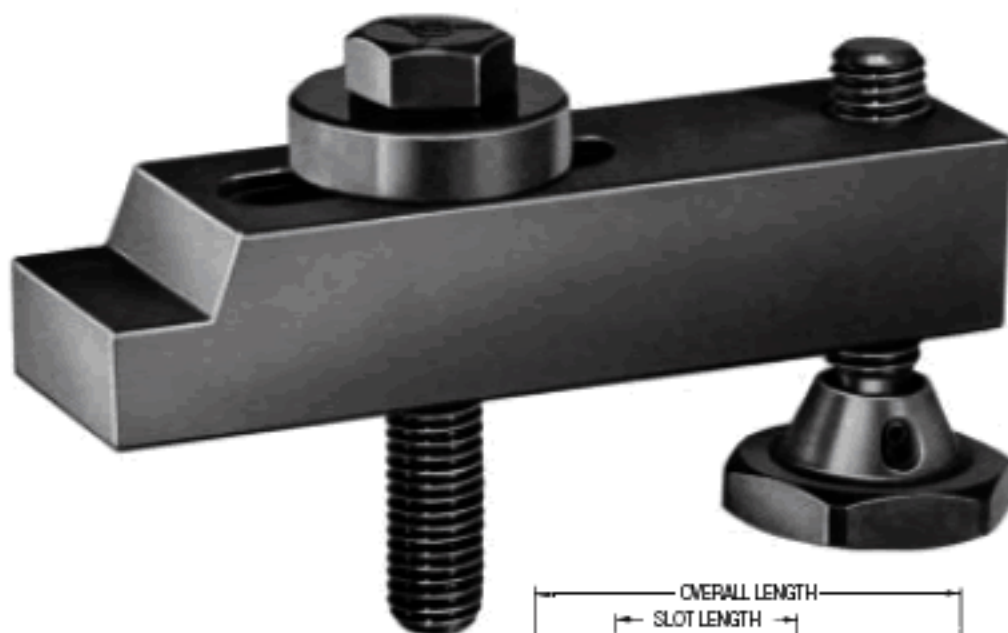

For Clamping Screw Diameter	Clamping Screw Size Supplied With Assembly Diameter x Length	Mold Clamp Body Specifications				Complete Assembly Part Number	Price Each	Individual Clamp Bodies Part Number	Price Each
		Thickness	Width	Slot Length	Overall Length				
5/8	5/8-11 x 3-3/4	1-1/4	1-3/4	2-5/8	6	TAC-5861-A	\$36.25	XHD-5861	\$24.25
				3-5/8	7-1/2	TAC-5876-A	\$39.00	XHD-5876	\$27.00
3/4	3/4-10 x 4-1/2	1-1/2	2	2-3/4	6-1/2	TAC-7566-A	\$50.25	XHD-7566	\$35.50
				3-3/4	8	TAC-7581-A	\$53.25	XHD-7581	\$38.50
				4-3/4	9-1/2	TAC-7596-A	\$56.50	XHD-7596	\$41.75
1"	1"-8 x 5-1/2	1-3/4	2-1/2	3	8	TAC-1009-A	\$71.00	XHD-1009	\$44.00
				5	11	TAC-1012-A	\$78.75	XHD-1012	\$51.75
1-1/4	1-1/4-7 x 6	1-3/4	3	5-1/2	13	TAC-1250-A	\$144.50	XHD-1250	\$94.25
1-1/2	1-1/2-6 x 6	1-3/4	3-1/2	5-3/4	13-1/2	TAC-1500-A	\$159.75	XHD-1500	\$104.25

HTC/TOPS-ALL Clamps, Inc.

26627 West 8 Mile Road, Redford, MI 48240 ☐ Phone: (313) 533-7500 ☐ Fax: (313) 533-1040 ☐ www.htc-topsallclamps.com

Open Slot Style Mold Clamp Assemblies (shown)

Heavy Duty
(All Clamp Styles and Sizes Available with Non-Swivel Base)



For Clamping Screw Diameter	Clamping Screw Size Supplied With Assembly Diameter x Length	Mold Clamp Body Specifications				Complete Assembly Part Number	Price Each	Individual Clamp Bodies Part Number	Price Each
		Thickness	Width	Slot Length	Overall Length				
5/8	5/8-11 x 3-1/4	1"	1-3/4	2-3/4	4	CFC-584-A	\$19.75	HD-584	\$15.75
				3-1/4	5	CFC-585-A	\$21.50	HD-585	\$17.50
				3-3/4	6	CFC-586-A	\$23.50	HD-586	\$19.50
				4-1/4	7	CFC-587-A	\$25.25	HD-587	\$21.50
3/4	3/4-10 x 4	1-1/8	2	3-3/8	5	CFC-755-A	\$28.25	HD-755	\$21.75
				3-7/8	6	CFC-756-A	\$30.25	HD-756	\$23.75
				4-3/8	7	CFC-757-A	\$32.25	HD-757	\$25.75
				5-3/8	8	CFC-758-A	\$34.50	HD-758	\$28.00
1"	1"-8 x 4-1/2	1-1/2	2-1/2	6	10	CFC-110-A	\$51.75	HD-110	\$38.25

Enclosed Slot Style Clamp Assemblies for T-Slotted Machines

**Extra Heavy Duty
(with Swivel-Base Adjusting Screw)**



T-Slot Bolt Supplied With Assembly Diameter x Length	Mold Clamp Body Specifications				Complete Assembly Part Number	Price Each	Individual Clamp Bodies Part Number	Price Each
	Thickness	Width	Slot Length	Overall Length				
5/8 x 4-1/2	1-1/4	1-3/4	2-5/8	6	TBA-5861-A	\$40.50	XHD-5861	\$24.25
3/4 x 5	1-1/2	2	2-3/4	6-1/2	TBA-7566-A	\$56.75	XHD-7566	\$35.50
1" x 6	1-3/4	2-1/2	3	8	TBA-1009-A	\$79.50	XHD-1009	\$44.00

Other sizes available upon request!!

HTC/TOPS-ALL Clamps, Inc.

26627 West 8 Mile Road, Redford, MI 48240 ☐ Phone: (313) 533-7500 ☐ Fax: (313) 533-1040 ☐ www.htc-topsallclamps.com

Individual Mold Clamp Bodies

All Mold Clamp Bodies Built of Hardened Premium Quality Steel.
For Specifications and Ordering Numbers of Individual Clamp
Bodies, Refer to Mold Clamp Assembly Charts.



Do you have a special request? Call us, we can help!

Individual Accessory and Replacement Mold Clamp Parts

**Extra
Large
Adjusting
Screw
Assemblies**



**Hex
Head
Adjusting
Screw**



Part No.	Clamp Screw Dia.	Thread Size	Swivel Base Hex Size	Swivel Base Height	Overall Height	Price Each
H-585	5/8	5/8-11	1-3/4	7/8	3	\$8.00
H-755	3/4	3/4-10	2	7/8	3-1/2	\$9.50
H-1005	1	1-8	2-1/2	1-5/16	3-1/2	\$15.50
H-1505	1-1/4 & 1-1/2	1-1/2-6	3	1-5/8	5-5/8	\$29.00

Part No.	Clamp Screw Dia.	Thread Size	Head Thickness	Height Above Head	Price Each
H-58	5/8	5/8-11	7/16	2-1/2	\$1.75
H-75	3/4	3/4-10	1/2	2-1/2	\$2.25
H-100	1	1-8	5/8	2-1/2	\$5.00



High Strength: Grade 5, Hex Head Clamping Screws



Part No.	Length	Thread Size	Hex Size	Thickness	Price Each
S-1235	3-1/2	1/2-13	3/4	5/16	\$1.50
S-5832	3-1/4	5/8-11	15/16	25/64	\$1.25
S-5835	3-1/2	5/8-11	15/16	25/64	\$1.50
S-5837	3-3/4	5/8-11	15/16	25/64	\$1.75
S-7540	4	3/4-10	1-1/8	15/32	\$2.50
S-7545	4-1/2	3/4-10	1-1/8	15/32	\$2.75
S-1045	4-1/2	1-8	1-1/2	39/64	\$6.25
S-1050	5	1-8	1-1/2	39/64	\$6.50
S-1055	5-1/2	1-8	1-1/2	39/64	\$7.00
S-1256	6	1-1/4-7	1-7/8	3/4	\$16.75
S-1506	6	1-1/2-6	2-1/4	7/8	\$20.50

Other sizes and **Socket Cap Screws** available upon request!!



High Strength: T-Slot Bolts

Part No.	Length	Thread Size	Price Each
TB-5845	4-1/2	5/8-11	\$6.00
TB-7550	5	3/4-10	\$8.00
TB-1060	6	1-8	\$15.00

Extra Large No-Twist Rectangular Mold Washers



Part No.	Screw Dia. (I.D.)	Length	Thickness Above Clamp	Clamp Width	Price Each
SW-127	1/2	2-1/4	3/4	1-1/4	\$5.00
SW-587	5/8	2-1/4	3/4	1-1/4	\$4.50
SW-757	3/4	2-1/2	3/4	1-1/2	\$5.00
SW-1007	1	3	1	2	\$7.25

Extra Large Round Mold Washers



Part No.	Screw Dia. (I.D.)	O.D. Dia.	Thickness	Price Each
RW-586	5/8	1-3/4	1/2	\$3.00
RW-756	3/4	2	1/2	\$3.75
RW-1006	1	2-1/2	5/8	\$5.75
RW-1256	1-1/4	3	5/8	\$7.25
RW-1506	1-1/2	3-1/2	5/8	\$9.00

Round Mold Washers



Part No.	Screw Dia. (I.D.)	O.D. Dia.	Thickness	Price Each
RW-58	5/8	1-1/4	1/4	\$1.25
RW-75	3/4	1-1/2	1/4	\$2.00
RW-100	1	2	5/16	\$3.00

Heavy Duty Hex Nuts for T-Slot Bolts



Part No.	Thread Size	Hex Size	Thickness	Price Each
N-58	5/8-11	1-1/16	39/64	\$1.50
N-75	3/4-10	1-1/4	47/64	\$2.00
N-100	1-8	1-5/8	63/64	\$2.75

HTC/TOPS-ALL Clamps, Inc.

26627 West 8 Mile Road, Redford, MI 48240 ☐ Phone: (313) 533-7500 ☐ Fax: (313) 533-1040 ☐ www.htc-topsallclamps.com